

General Standards Corporation
High Performance Bus Interface Solutions

66-24DSI16WRC

Wide-Range 24-Bit, 16-Channel, 105KSPS Analog Input Module

With 16 Wide-Range (High-Level, Low-Level) Delta-Sigma Input Channels

Available in PMC, PCI, cPCI and PC104-Plus and PCI Express form factors as:

PMC66-24DSI16WRC:	PMC, single-width
PCI66-24DSI16WRC:	PCI, short length
cPCI66-24DSI16WRC:	cPCI, 3U
PC104P66-24DSI16WRC:	PC104-Plus
PCIe-24DSI16WRC:	PCI Express
PCIe104-24DSI16WRC:	PCIe, one lane on PC/104 form factor

See Ordering Information for details.

Call for the availability of other form factors, such as XMC, 104-Express, CCPMC, etc.

Features Include:

- 16 wide-range differential 24-Bit simultaneously-sampled analog input channels.
- Input sample rates to 105 Kilosamples per second per channel.
- Software-selectable analog input ranges of $\pm 10\text{mV}$, $\pm 100\text{mV}$, $\pm 1\text{V}$, $\pm 10\text{V}$.
- Delta-Sigma input conversion minimizes or eliminates the need for antialias filtering.
- 256K-sample analog input FIFO buffer.
- Continuous and Burst One-shot) sampling modes.
- Sample clock source selected as internal or external.
- Supports multiboard synchronization of analog inputs.
- On-demand internal offset and gain autocalibration of all analog inputs.
- 4-Bit bi-directional digital port.
- Software-controlled master clock frequency fine-adjustment.
- 66MHz PCI support, with universal 5V/3.3V signaling and DMA support.
- Large FPGA supports optional features such as counter/timers.
- Available on adapters for alternate form factors, including PCI, cPCI and PC104-Plus, as well as PCI-Express, PCIX and cPCIX.

Applications:

- | | | |
|-----------------|-----------------------|---------------------------|
| ✓ Sonar Arrays | ✓ Voltage Acquisition | ✓ Phase Comparison |
| ✓ Analog Inputs | ✓ Acoustic Research | ✓ Audio Waveform Analysis |

PRELIMINARY

REV 032614

General Standards Corporation

8302A Whitesburg Drive · Huntsville, AL 35802

Phone: (256) 880-8787 or (800) 653-9970 FAX: (256) 880-8788 Email: Solutions@GeneralStandards.com

Overview:

The 16-channel 24DSI16WRC analog input module provides high-density 24-bit analog input resources on a standard single-width PMC. Optimized for flexibility and performance, the board is ideal for a wide variety of applications, ranging from simple precision voltage measurements, to the analysis of complex audio signals and waveforms.

Functional Description:

Each of 16 analog input channels contains a lowpass image filter, and a delta-sigma A/D converter that provides inherent antialias suppression and sharp cutoff lowpass filtering. An internal voltage reference can be applied to all channels to support selftest operations and autocalibration. Gain and offset trimming is performed by applying correction values that are determined during on-demand autocalibration. A linear-phase digital antialiasing filter rejects out-of-band signals, and a lowpass analog filter reject those interference signals that fall within the harmonic images of the digital filter.

An internal sample-rate generator is adjustable over a 2:1 frequency range, and is divided down within the local controller to provide individual channel sample rates from 0.4KSPS to 105KSPS in the high-speed clocking mode, or from 0.2KSPS to 52KSPS in high-resolution and low-power modes. Conversion data from all active channels is transferred to the PCI bus through a 256K-sample data buffer that is supported by two DMA channels. Multiple channels can be synchronized to perform sampling in “lockstep”, either by a software command, or by external hardware sync and clock input signals.

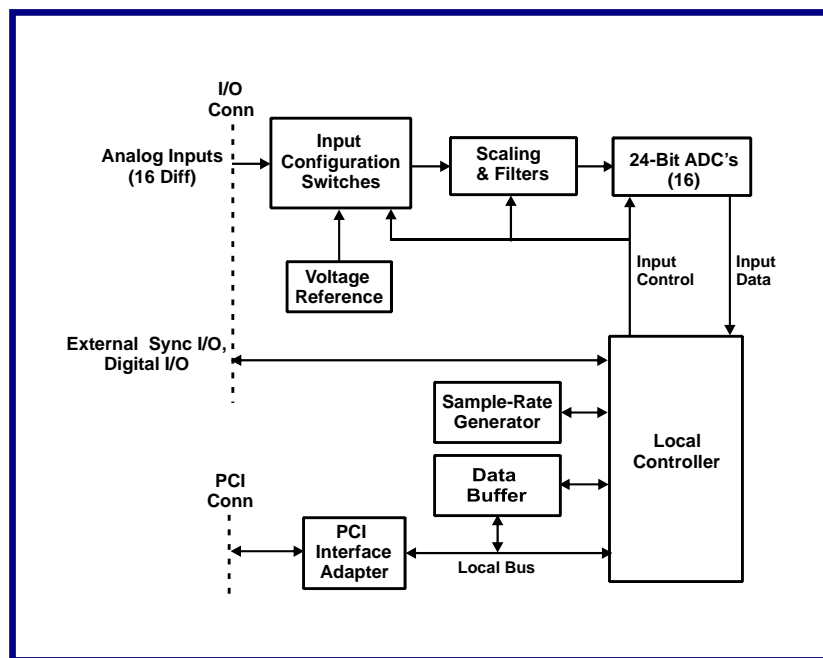

Figure 1. 24DSI16WRC; Functional Organization

This product is functionally compatible with the IEEE PCI local bus specification Revision 2.3. System input/output connections are made at the front panel through a high-density 80-Pin I/O connector. Power requirements consist of +5 VDC, in compliance with the PCI specification, and operation over the specified temperature range is achieved with conventional air cooling.

General Standards Corporation

8302A Whitesburg Drive · Huntsville, AL 35802

Phone: (256) 880-8787 or (800) 653-9970 FAX: (256) 880-8788 Email: Solutions@GeneralStandards.com

ELECTRICAL SPECIFICATIONS

At +25 °C, with specified operating conditions.

Input Characteristics:

Configuration:	16 differential input channels. 8 and 4-channel configurations available.
Voltage Range:	Software Configurable as $\pm 10V$, $\pm 1V$, $\pm 100mV$ or $\pm 10mV$. (Contact factory for availability of $\pm 10V$, $\pm 5V$, $\pm 2.5V$ or $\pm 1.25V$ range set)
Input Impedance:	1.0 Megohm typical, in parallel with 20 pF. 2.0 Megohms line-line.
Common Mode Rejection:	80dB to 15kHz on $\pm 10V$ range; 95dB on lower ranges; typical
Common Mode Range:	± 11 Volts with zero normal-mode input
Oversvoltage Protection:	± 25 -Volt transients with power applied; ± 12 Volts with power removed

Transfer Characteristics:

Conversion Architecture:	24-Bit Delta-Sigma															
Sample Rate:	0.4-105 kilosamples per second per channel in high-speed mode, 0.2-52 kilosamples per second in high-resolution and low-power modes.															
Oversampling Factor:	x128 in high-resolution mode: x64 in high-speed and low-power modes.															
DC Accuracy: (Mean composite error after autocalibration)	<table><thead><tr><th>Input Range</th><th>Midrange (Zero) Accuracy</th><th>Gain Accuracy</th></tr></thead><tbody><tr><td>$\pm 10V$</td><td>$\pm 1.0mv$</td><td>$\pm 6.0mv$</td></tr><tr><td>$\pm 1V$</td><td>$\pm 0.3mv$</td><td>$\pm 1.0mv$</td></tr><tr><td>$\pm 100mV$</td><td>$\pm 0.08mv$</td><td>$\pm 0.20mv$</td></tr><tr><td>$\pm 10mV$</td><td>$\pm 0.02mv$</td><td>$\pm 0.05mv$</td></tr></tbody></table>	Input Range	Midrange (Zero) Accuracy	Gain Accuracy	$\pm 10V$	$\pm 1.0mv$	$\pm 6.0mv$	$\pm 1V$	$\pm 0.3mv$	$\pm 1.0mv$	$\pm 100mV$	$\pm 0.08mv$	$\pm 0.20mv$	$\pm 10mV$	$\pm 0.02mv$	$\pm 0.05mv$
Input Range	Midrange (Zero) Accuracy	Gain Accuracy														
$\pm 10V$	$\pm 1.0mv$	$\pm 6.0mv$														
$\pm 1V$	$\pm 0.3mv$	$\pm 1.0mv$														
$\pm 100mV$	$\pm 0.08mv$	$\pm 0.20mv$														
$\pm 10mV$	$\pm 0.02mv$	$\pm 0.05mv$														
Passband	DC to typically 45 percent of the selected sample rate.															
Passband Ripple:	$\pm 0.02dB$ maximum															
Stopband threshold:	Typically 55 percent of the selected sample rate.															
Stopband Attenuation:	98dB typical.															
-3dB Bandwidth	DC to typically 49 percent of the selected sample rate.															
Integral Nonlinearity (INL)	0.001 percent of fullscale range; typical.															
No Missing Codes	24 Bits.															
Dynamic Range:	103dB; typical in high-resolution mode, 100dB in all other modes.															
SINAD:	$\pm 10V$ Range: 100dB typical to 20 kHz; 85 dB typical to 50 kHz. $\pm 10mV$ Range: 80dB typical to 1 kHz; 60 dB typical to 5 kHz.															
Interchannel Crosstalk:	-96dB typical to 40kHz															
Phase Skew:	Typically less than 100ns (0.1-Degree for $F_{sig} = 5kHz$), with $F_{sig}/F_{samp} < 0.35$; channel-channel (board-board for multiboard configurations), excluding noise, with high-frequency image filter.															
Antialias Filtering:	Each ADC provides linear-phase digital lowpass filtering as indicated for "passband" and "stopband". In addition to the digital filter, a 2 nd -order Butterworth lowpass analog image filter in each channel provides a -3dB cutoff frequency of approximately 150kHz to suppress images from the digital filter. Optional alternative image filter frequencies are available, and should be selected to be well above the expected passband.															

Operating Modes and Controls:

Organization:	All input channels operate at the same sample rate, controlled by division of an internal or external rate generator frequency.
Sampling Clock I/O:	The sampling clock can be derived either from an internal rate generator, or from a TTL or LVDS external hardware input. Multiple boards can be locked to a common clock by daisy-chaining the output clock from each board to the input clock of the next board in the chain. Any number of boards can be daisy-chained together, with a typical propagation delay of 10ns introduced per board. The 'star-configuration' also is supported.
Internal Rate Generator:	An internal PLL rate generator provide sample rates from 0.2 KSPS to 105 KSPS. The frequency of the generator is controlled by the ratio of two 10-Bit integers, and setting accuracy is 25 PPM.
Synchronization:	Daisy-chained or 'star-configuration' hardware sync inputs and outputs can be used to synchronize sampling among multiple boards.
Burst Timing:	Triggered burst sampling can be timed either internally or externally.
Data Format:	Software-selectable as either offset binary or two's complement. Width of the data field is selectable as 16, 18, 20 or 24 bits.
Channel Tags:	A 4-bit channel tag is appended to each input data value.
Buffer Access:	The input buffer FIFO is accessed through either of two DMA channels, with both block-mode and demand-mode transfers supported.
Master Clock Adjustment:	Master-clock frequency software-adjustable approximately ± 100 PPM around center frequency.
Auxiliary External Sync I/O:	A 6-pin connector on the back of the module provides clock and sync I/O capability within the enclosure.
Digital I/O	Four TTL digital I/O lines are individually selectable as either inputs or outputs. Maximum output loading is ± 8 mA. Input loading consists of 33K-ohms resistors to +3.3V

PCI Compatibility:

Conforms to PCI Specification 2.3: D32, 33/66MHz, universal (3.3V/5V) signaling.
Two-Channel DMA as bus master in block and demand modes.

Power Requirements:

+5.0 VDC ± 0.25 VDC at:

12-Channel Configuration: 1.3 Amps typical, 1.7 Amps, maximum

16-Channel Configuration: 1.9 Amps typical, 2.5 Amps, maximum

Mechanical Characteristic:

Dimensions (HxWxD): 13.5 mm (0.53 in) x 74.0 mm (2.91 in) x 149.0 mm (5.87 in)

(Mechanical dimensions are shown for the native PMC form factor. See Ordering Information.)

General Standards Corporation

8302A Whitesburg Drive · Huntsville, AL 35802

Phone: (256) 880-8787 or (800) 653-9970 FAX: (256) 880-8788 Email: Solutions@GeneralStandards.com

Environmental Specifications:

Ambient Temperature Range:	
Standard Temperature:	Operating: 0 to +70 Degrees Celsius * Storage: -40 to +85 Degrees Celsius
Extended Temperature:	Operating: -40 to +80 Degrees Celsius * Storage: -40 to +85 Degrees Celsius * Air temperature at board surface.
Relative Humidity:	0 to 95%, non-condensing
Altitude:	Operation to 10,000 ft.
Cooling:	Conventional air cooling; 150 LFPM

Ordering Information:

Specify the basic product model number followed by an option suffix "-A-B-C", as indicated below. For example, model number PMC66-24DSI16WRC-16-SF-0 describes a PMC module with 16 input channels, standard image filter frequency, and no custom features. For industrial (extended) temperature operation, add "-I" at the end of the model number.

Basic Model Number	Form Factor
PMC66-24DSI16WRC	PMC (Native)
PCI66-24DSI16WRC ^{1,2}	PCI, short length
cPCI66-24DSI16WRC ^{1,2}	cPCI, 3U
PC104P66-24DSI16WRC ^{1,3}	PC104-Plus
PCIe-24DSI16WRC ^{1,3}	PCI-Express
PCIe104-24DSI16WRC ^{1,3}	PCIe104

¹ Contact factory for availability in native form factors, or for form factors not listed here.

² PMC module installed and tested on an adapter, with mechanical and functional equivalency.

³ PMC module installed and tested on an adapter, with functional equivalency.

Optional Parameter	Value	Specify Option As:
Number of Input Channels	4 Channels	A = 4
	8 Channels	A = 8
	16 Channels	A = 16
Image Filter -3dB Frequency	Standard 150kHz	B = SF
	Custom Frequencies:	B = CFxK *
	No Filter:	B = NF
Custom Features	No custom features	C = 0

* "x" indicates filter frequency in kilohertz. ±15% frequency accuracy, 1kHz-300kHz. Contact factory for availability of specific frequencies.

General Standards Corporation

8302A Whitesburg Drive · Huntsville, AL 35802

Phone: (256) 880-8787 or (800) 653-9970 FAX: (256) 880-8788 Email: Solutions@GeneralStandards.com

SYSTEM I/O CONNECTIONS

Table 1. System I/O Connector

ROW-A		ROW-B	
PIN	SIGNAL	PIN	SIGNAL
1	INP00 LO	1	INP09 LO
2	INP00 HI	2	INP09 HI
3	INPUT RTN	3	INPUT RTN
4	INPUT RTN	4	INPUT RTN
5	INP01 LO	5	INP10 LO
6	INP01 HI	6	INP10 HI
7	INPUT RTN	7	INPUT RTN
8	INPUT RTN	8	INPUT RTN
9	INP02 LO	9	INP11 LO
10	INP02 HI	10	INP11 HI
11	INPUT RTN	11	INPUT RTN
12	INPUT RTN	12	INPUT RTN
13	INP03 LO	13	INP12 LO
14	INP03 HI	14	INP12 HI
15	INPUT RTN	15	INPUT RTN
16	INPUT RTN	16	INPUT RTN
17	INP04 LO	17	INP13 LO
18	INP04 HI	18	INP13 HI
19	INPUT RTN	19	INPUT RTN
20	INPUT RTN	20	INPUT RTN
21	INP05 LO	21	INP14 LO
22	INP05 HI	22	INP14 HI
23	INPUT RTN	23	INPUT RTN
24	INPUT RTN	24	INPUT RTN
25	INP06 LO	25	INP15 LO
26	INP06 HI	26	INP15 HI
27	INPUT RTN	27	INPUT RTN
28	INPUT RTN	28	INPUT RTN
29	INP07 LO	29	DIG IO 00
30	INP07 HI	30	DIGITAL RTN
31	INPUT RTN	31	DIG IO 01
32	INPUT RTN	32	DIGITAL RTN
33	INP08 LO	33	DIG IO 02
34	INP08 HI	34	DIGITAL RTN
35	INPUT RTN	35	DIG IO 03
36	DIGITAL RTN	36	DIGITAL RTN
37	EXT CLK INP LO	37	EXT CLK OUT LO
38	EXT CLK INP HI *	38	EXT CLK OUT HI *
39	EXT SYNC INP LO	39	EXT SYNC OUT LO
40	EXT SYNC INP HI *	40	EXT SYNC OUT HI *

* TTL signal levels when TTL sync I/O is selected. Otherwise LVDS.

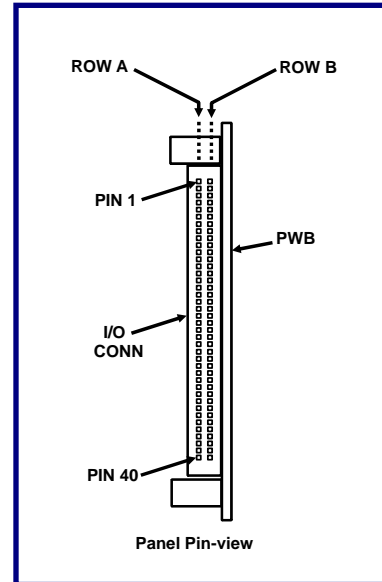

Figure 2. System I/O Connector

System Mating Connector:

Standard 80-pin 0.050" dual-ribbon socket connector:

Robinson Nugent **P50E-080S-TG** or equivalent.

Table 2. Aux Sync I/O Connector

PIN	SIGNAL
1	DIGITAL RTN
2	AUX CLOCK
3	DIGITAL RTN
4	AUX SYNC
5	DIGITAL RTN
6	Reserved. Ground or leave disconnected.

General Standards Corporation assumes no responsibility for the use of any circuits in this product. No circuit patent licenses are implied. Information included herein supersedes previously published specifications on this product and is subject to change without notice.

General Standards Corporation

8302A Whitesburg Drive · Huntsville, AL 35802

Phone: (256) 880-8787 or (800) 653-9970 FAX: (256) 880-8788 Email: Solutions@GeneralStandards.com