

Jade 52141A

1-channel 6.4 GHz A/D; 2-channel 3.2 GHz A/D;
2-channel 6.4 GHz D/A
3U VPX board with Kintex UltraScale FPGA

Complete radar and software radio interface solution

- Radar and communication receiver and transmitter
- Electronic Warfare transponder
- Waveform signal generator
- Wideband data acquisition
- Remote monitoring
- Sensor interfaces



The Jade® 52141A is a high-speed analog-to-digital and digital-to-analog converter with programmable DDCs (digital downconverters) and DUCs (digital upconverters). It is suitable for connection to HF or IF ports of a communications or radar system. Its built-in data capture and generator features offer an ideal turnkey solution as well as a platform for developing and deploying custom FPGA-processing IP.

It includes a 6.4 GHz, 12-bit A/D converter, dual 6.4 GHz, 14-bit D/As and a large DDR4 memory. In addition to supporting PCI Express Gen. 3 as a native interface, the 52141A includes optional high-bandwidth connections to the Kintex UltraScale FPGA for custom digital I/O.

FEATURES

- Xilinx® Kintex® UltraScale™ FPGA
- Supports VITA-49.2 VITA Radio Transport standard
- One-channel mode with 6.4 GHz, 12-bit A/D
- Two-channel mode with 3.2 GHz, 12-bit A/Ds
- Programmable DDCs (digital downconverters)
- Two 6.4 GHz, 14-bit D/As
- Programmable DUCs (digital upconverters)
- 5 GB of 2400 MHz DDR4 SDRAM
- μ Sync clock/sync bus for multimodule synchronization
- PCI Express interface (Gen. 1, 2 & 3) up to x4
- Optional LVDS port and gigabit serial connections for custom FPGA I/O
- Compatible with VITA-46, VITA-48 and VITA-65 (OpenVPX™ Specification)
- Ruggedized and conduction-cooled versions
- Navigator Design Suite for software and custom IP development

52141A BLOCK DIAGRAM

Click on a block for more information.

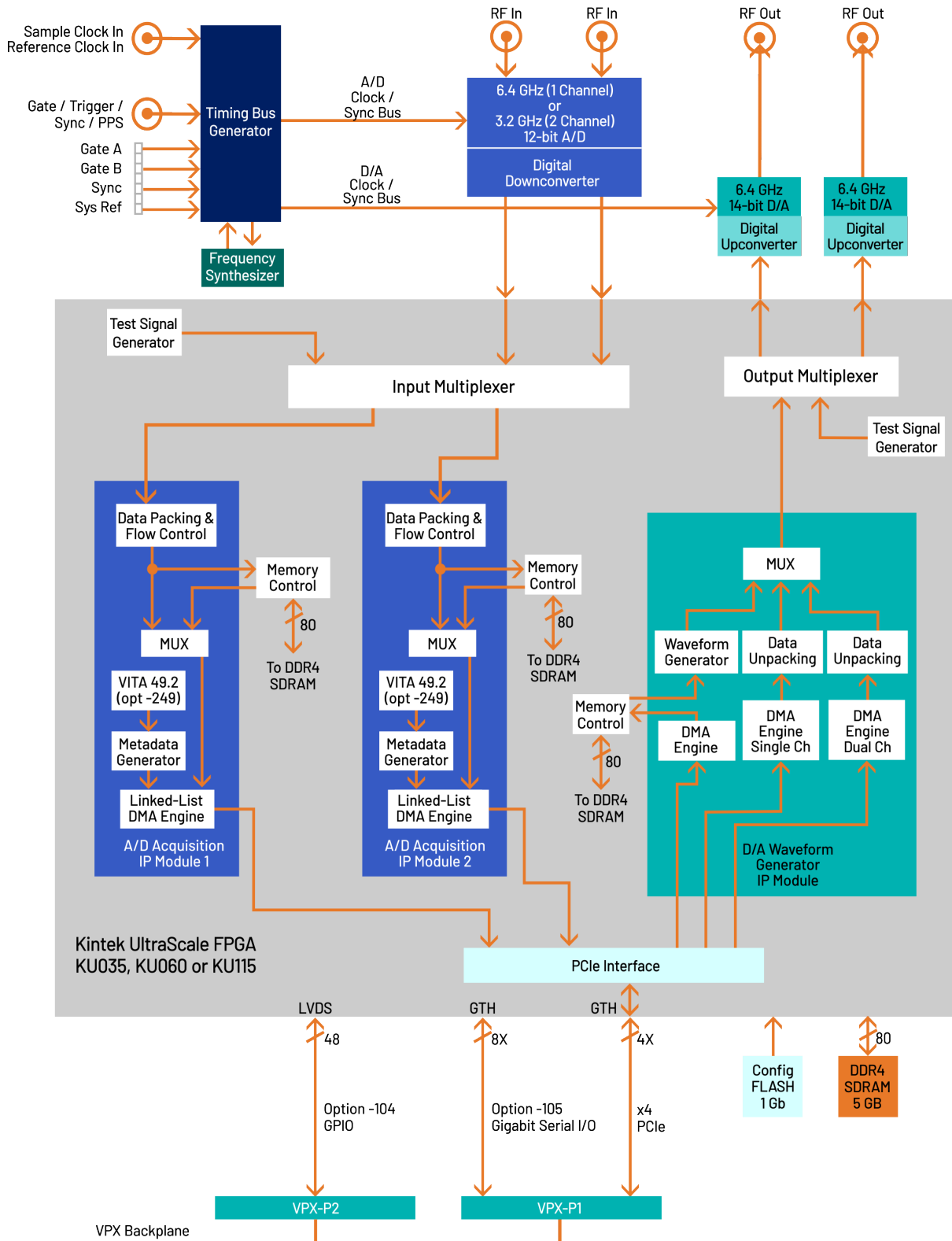

THE JADE ARCHITECTURE

Evolved from the proven designs of Mercury's Cobalt[®] and Onyx[®] families, Jade[®] raises the processing performance while lowering the overall power requirements by building on the Xilinx family of Kintex UltraScale FPGAs. As the central feature of the board architecture, the FPGA has access to all data and control paths, enabling factory-installed functions as well as providing an ideal platform for user-created intellectual property (IP).

Each member of the Jade family is delivered with factory-installed applications ideally matched to the board's analog interfaces. The 52141A factory-installed functions include two A/D acquisition and a D/A waveform generator IP module. In addition, IP modules for DDR4 SDRAM memories, a controller for all data clocking and synchronization functions, a test signal generator and a PCIe interface complete the factory-installed functions and enable the 52141A to operate as a complete turnkey solution, without the need to develop any FPGA IP.

XILINX KINTEX ULTRASCALE FPGAS

Depending on the requirements of the processing task, the Kintex Ultrascale can be selected from a range of FPGAs: KU035 through KU115. The KU115 features 5520 DSP48E2 slices and is ideal for modulation/demodulation, encoding/decoding, encryption/decryption, and channelization of the signals between transmission and reception. For applications not requiring large DSP resources or logic, a lower-cost FPGA can be installed.

A/D CONVERTER STAGE

The board's analog interface accepts analog HF or IF inputs on a pair of front panel SSMC connectors with transformer-coupling into a Texas Instruments ADC12DJ3200 12-bit A/D. The converter operates in single-channel interleaved mode with a sampling rate of 6.4 GHz and an input bandwidth of 7.9 GHz; or, in dual-channel mode with a sampling rate of 3.2 GHz and input bandwidth of 8.1 GHz.

The A/D built-in digital down-converters (DDCs) support 2x decimation in real output mode and 4x, 8x, or 16x decimation in complex output mode. The A/D digital outputs are delivered into the Kintex UltraScale FPGA for signal processing, data capture or for routing to other module resources.

A/D ACQUISITION IP MODULES

The 52141A features two A/D Acquisition IP Modules for easily capturing and moving data. Each module can receive data from either of the two A/Ds, or a test signal generator. Each acquisition module has a DMA engine for efficiently moving A/D data through the PCIe interface.

These powerful linked-list DMA engines are capable of a unique Acquisition Gate Driven mode. In this mode, the length of a transfer performed by a link definition need not be known prior to data acquisition; rather, it is governed by the length of the acquisition gate. This is extremely useful in applications where an external gate drives acquisition and the exact length of that gate is not known or is likely to vary.

For each transfer, the DMA engine can automatically construct metadata packets containing A/D channel ID, a sample-accurate time stamp, and data length information. These actions simplify the host processor's job of identifying and executing on the data.

D/A WAVEFORM GENERATOR IP MODULE

The 52141A factory-installed functions include a sophisticated D/A Waveform Generator IP module. It allows users to easily record to the dual D/As waveforms stored in either on-board memory or off-board host memory.

DIGITAL UPCONVERTER AND D/A STAGE

A Texas Instruments DAC38RF82 DUC (digital upconverter) and D/A accepts a baseband real or complex data stream from the FPGA and provides that input to the upconvert, interpolate and dual D/A stages. When operating as a DUC, it interpolates and translates real or complex baseband input signals. It delivers real or quadrature (I+Q) analog outputs to the dual 14-bit D/A converter. Analog output is through a pair of front panel SSMC connectors.

If translation is disabled, the DAC38RF82 acts as a dual interpolating 14-bit D/A. In both modes the DAC38RF82 provides interpolation factors from 1x to 24x.

VITA 49.2 RADIO TRANSPORT STANDARD

VITA 49.2 is a data transport protocol for conveying digitized signal information among signal acquisition/generation and processing elements in a communication, radar or similar system. The 52141A implements the VITA 49 packet format for the ADC/DDC data being transferred to the host memory via DMA.

VITA 49.2 packet elements always supported are:

- Signal Data Packet Type
- Stream Identifier
- Integer Seconds Timestamp
- Fractions Seconds Timestamp
- Trailer

Programmable elements are:

- Packet Size
- Stream Identifier
- Trailer

The Timestamp is automatically inserted from the metadata engine. After initialization an externally applied 1 PPS pulse will increment the Integer Seconds Timestamp. A division of the sample clock will increment the fractional seconds timestamp and this count is reset by the 1 PPS pulse.

VITA 49 packets sent via DMA to the DAC/DUC for output will have the header, stream ID, timestamp and trailer removed leaving only the signal data to be transmitted.

CLOCKING AND SYNCHRONIZATION

The 52141A accepts a sample clock via a front panel SSMC connector. A second front panel SSMC accepts a TTL signal that can function as Gate, PPS or Sync.

A front panel μ Sync bus connector allows multiple modules to be synchronized, ideal for multichannel systems. The μ Sync bus includes gate, reset, and in and out reference clock signals. The Model 7892 high-speed sync module can be used to drive the sync bus to synchronize multichannel systems.

MEMORY RESOURCES

The 52141A architecture supports a 5 GB bank of DDR4 SDRAM memory. User-installed IP along with the Mercury-supplied DDR4 controller core within the FPGA can take advantage of the memory for custom applications.

PCI EXPRESS INTERFACE

The 52141A includes an industry standard interface fully compliant with PCI Express Gen. 1, 2, and 3 bus specifications. Supporting PCIe links up to x4, the interface includes multiple DMA controllers for efficient transfers to and from the module.

NAVIGATOR DESIGN SUITE

For applications that require specialized functions, the Navigator Design Suite allows customers to fully utilize the processing power of the FPGA. It includes an FPGA design kit for integrating custom IP into the factory-shipped design, and a board support package for creating host applications for control of all hardware and FPGA IP-based functions.

The **Navigator FPGA Design Kit (FDK)** for the Xilinx® Vivado® Design Suite includes the complete Vivado project folder for each Jade product with all design files for the factory-installed FPGA IP. Vivado’s IP Integrator is a graphical design entry tool that visually presents the complete block diagram of all IP blocks so the developer can access every component of the Jade design. Developers can quickly import, delete, and modify IP blocks and change interconnection paths using simple mouse operations.

Navigator FDK includes an IP core library of more than 100 functions representing a wealth of resources for DSP, data formatting, timing, and streaming operations, all based on the powerful AXI4 standard. Multilevel documentation for each IP core is a mouse click away, and fully consistent with Xilinx IP cores.

The **Navigator Board Support Package (BSP)** provides software support for Jade boards. It enables operational control of all hardware functions on the board and IP functions in the FPGA. The BSP structure is designed to complement the functions of the FDK by maintaining a one-to-one relationship between FDK and BSP components. For each IP block found in the FDK library, a matching software module can be found in the BSP. This organization simplifies the creation and editing of software to support new IP functions and modifications to existing IP cores.

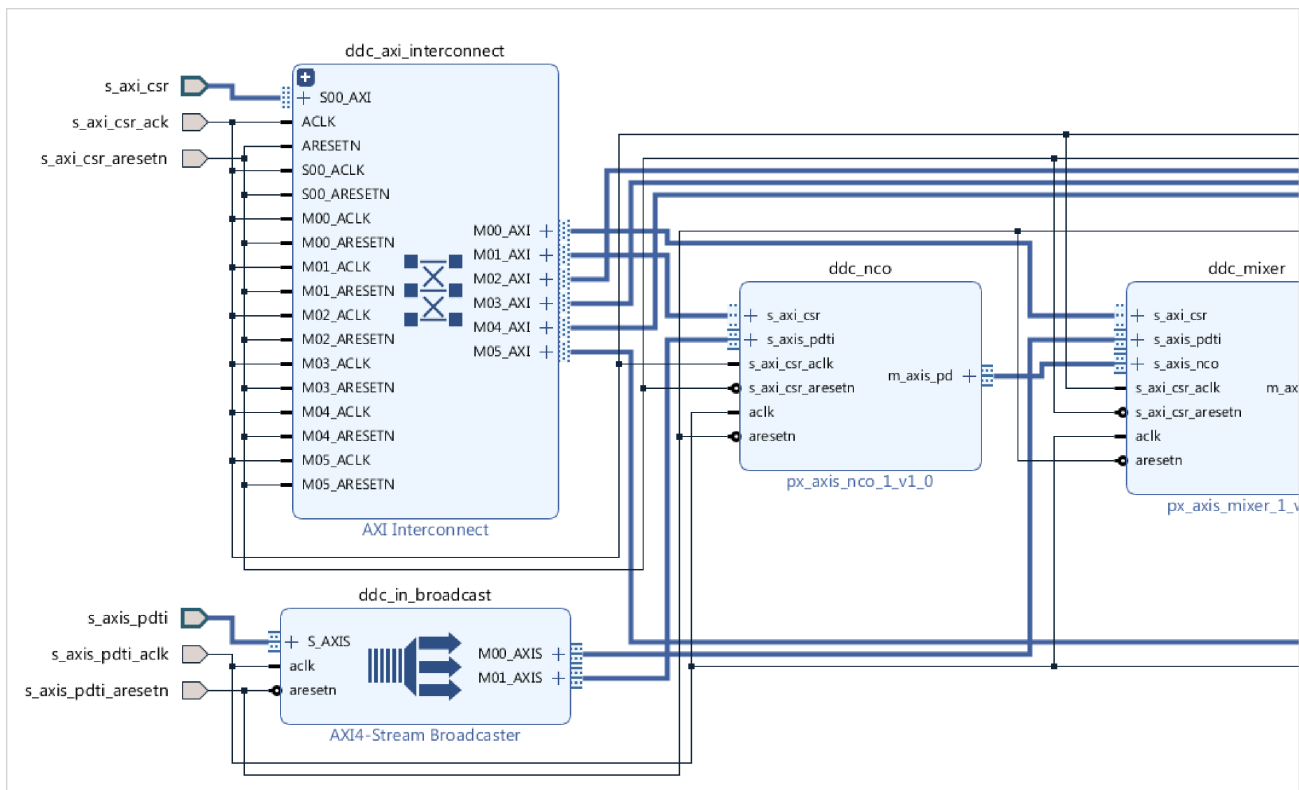

Navigator IP FPGA Design viewed in IP Integrator

NAVIGATOR BOARD SUPPORT PACKAGE

NAVIGATOR FPGA DESIGN KIT

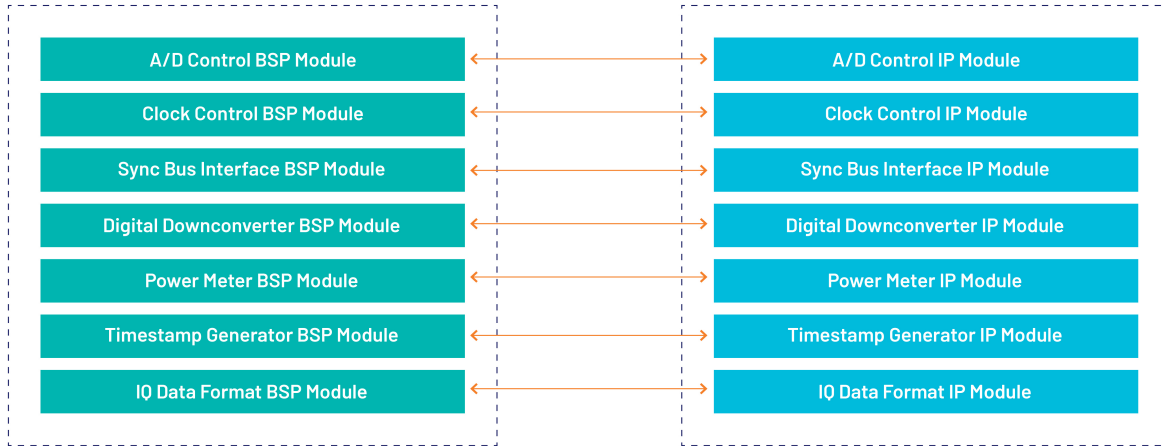

Because all Jade boards are shipped with a full suite of built-in IP functions and numerous software examples, new applications can be developed by building on the provided software examples or built entirely new with the BSP extensive libraries. All BSP libraries are provided as C-language source for full access and code transparency.

The Navigator BSP includes the **Signal Viewer**, a full-featured analysis tool, that displays data in time and frequency domains. Built-in measurement functions display 2nd and 3rd harmonics, THD (total harmonic distortion), and SINAD (signal to noise and distortion). Interactive cursors allow users to mark data points and instantly calculate amplitude and frequency of displayed signals. With the Signal Viewer users can install the Jade board and Navigator BSP and start viewing analog signals immediately.

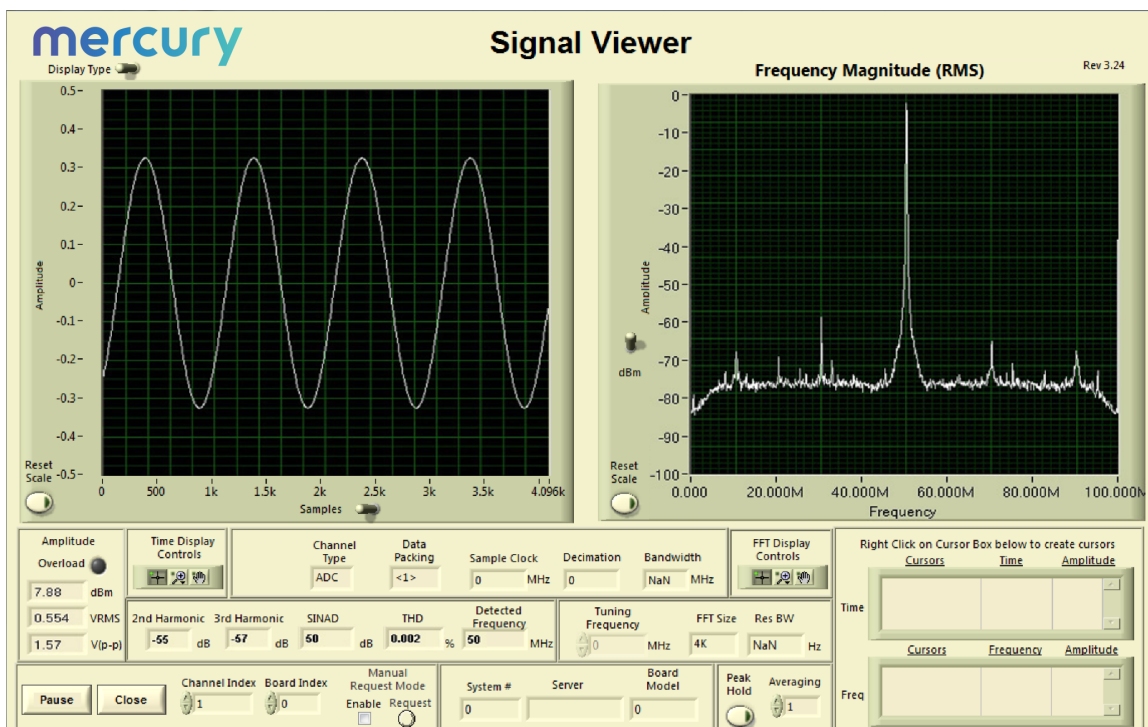

FRONT PANEL CONNECTIONS

The front panel includes seven SSMC coaxial connectors for input/output of analog RF, clock, and trigger, signals, and a 12-pin Sync Bus input connector. The front panel also includes seven LED indicators.

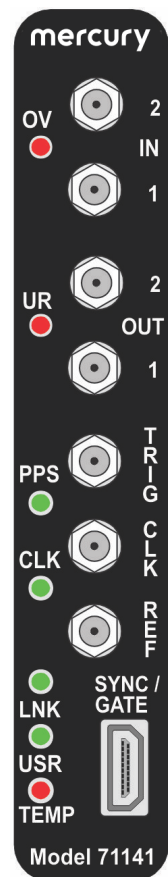

- **ADC Overload LED:** There is one red **OV** (overload) LED for all ADC inputs. This LED indicates either an overload detection in one of the ADC12DJ3200s, or an ADC FIFO overrun.
- **Analog Input Connectors:** Two SSMC coaxial connectors, labeled **In 1** and **IN 2**: one for each ADC input channel.
- **DAC Underrun LED:** One red underrun **UR** LED for both DAC outputs. This LED illuminates when the DAC38RF82 FIFO is out of data.
- **Analog Output Connectors:** Two SSMC coaxial connectors, labeled **OUT 1** and **OUT 2**: one for each DAC38RF82 output channel.
- **PPS LED:** The green **PPS** LED illuminates when a valid PPS signal is detected. The LED will blink at the rate of the PPS signal.
- **Trigger Input Connector:** One SSMC coaxial connector, labeled **TRIG**, for input of an external trigger.
- **Clock LED:** The green **CLK** LED illuminates when a valid sample clock signal is detected. If the LED is not illuminated, no clock has been detected and no data from the input stream can be processed.
- **Clock Input Connector:** One SSMC coaxial connector, labeled **CLK**, for input of an external sample clock.
- **Reference Clock Input Connector:** The SSMC coaxial connector, labeled **REF**, for input of an external reference clock.
- **Link LED:** The green **LNK** LED indicates the link speed when a valid link has been established over the PCIe interface, as follows: Gen 1 - LED blinks slowly (less than once per second); Gen 2 - LED blinks about once per second; Gen 3 - LED will be constantly on.

- **Sync Bus Connector:** The 19-pin μ Sync front panel connector, labeled **SYNC/GATE**, provides sync and gate input signals for A/D and D/A Processing.
- **User LED:** The green **USR** LED is for user applications.
- **Over Temperature LED:** The red **TMP** LED illuminates when an over-temperature or over-voltage condition is indicated by any of the temperature/voltage sensors on the PCB.

SPECIFICATIONS

Front Panel Analog Signal Inputs

Input Type: Transformer-coupled, front panel female SSMC connectors

A/D Converters

Type: ADC12DJ3200

Sampling Rate: Single-channel mode: 6.4 GHz; dual-channel mode: 3.2 GHz

Resolution: 12 bits

Input Bandwidth: single-channel mode: 7.9 GHz; dual-channel mode: 8.1 GHz

D/A Converters

Type: Texas Instruments DAC38RF82

Output Sampling Rate: 6.4 GHz.

Resolution: 14 bits

Sample Clock Source

Front panel SSMC connector

Timing Bus

19-pin μ Sync bus connector includes sync and gate/trigger inputs, CML

External Trigger Input

Type: Front panel female SSMC connector, LVTTTL

Function: Programmable functions include: trigger, gate, sync and PPS

Field Programmable Gate Array

Standard: Xilinx Kintex UltraScale XCKU035-2

- Option -084: Xilinx Kintex UltraScale XCKU060-2
- Option -087: Xilinx Kintex UltraScale XCKU115-2

Custom I/O

Option -104: provides 24 pairs of LVDS connections between the FPGA and the VPX P2 connector for custom I/O.

Option -105: provides an 8X gigabit link between the FPGA and the VPX P1 connector to support serial protocols.

Memory

Type: DDR4 SDRAM
 Size: 5 GB
 Speed: 1200 MHz (2400 MHz DDR)

PCI-Express Interface

PCI Express Bus: Gen. 1, 2 or 3: x4

Environmental

Standard: L0 (air-cooled)

- Operating Temp: 0° to 50° C
- Storage Temp: -20° to 90° C
- Relative Humidity: 0 to 95%, non-condensing

Option -702: L2 (air-cooled)

- Operating Temp: -20° to 65° C
- Storage Temp: -40° to 100° C
- Relative Humidity: 0 to 95%, non-condensing

Option -763: L3 (conduction-cooled)

- Operating Temp: -40° to 70° C
- Storage Temp: -50° to 100° C
- Relative Humidity: 0 to 95%, non-condensing

Physical

Dimensions: 3U VPX board

- Depth: 170.61 mm (6.717 in)
- Height: 100 mm (3.937 in)

Weight: Approximately 14 oz (400 grams)

ORDERING INFORMATION

Model	Description
52141A	1-Ch. 6.4 GHz or 2-Ch. 3.2 GHz A/D, 2-Ch. 6.4 GHz D/A, Kintex UltraScale FPGA - 3U VPX

Options:

-084	XCKU060-2 FPGA
-087	XCKU115-2 FPGA
-104	LVDS FPGA I/O through P14 connector
-105	Gigabit serial FPGA I/O
-702	Air-cooled, Level 2
-763	Conduction-cooled, Level 3

Contact Mercury for compatible option combinations and complete specifications of rugged and conduction-cooled versions. Options may change, so be sure to contact Mercury for the latest information.

ACCESSORY PRODUCTS

Model	Description
2171	Cable Kit: SSMC to SMA
5292	High-Speed Synchronizer & Distribution Board

DEVELOPMENT SYSTEMS

Mercury offers development systems for Jade products. They come with all pre-tested software and hardware ready for immediate operation. These systems are intended to save engineers and system integrators the time and expense associated with building and testing a development system that ensures optimum performance of Jade boards. Please [contact Mercury](#) to configure a system that matches your requirements.

FORM FACTORS

Jade products are available in standard form factors including 3U VPX, 6U VPX, PCIe, and XMC. The Jade Model 71141A XMC (8-Channel 250 MHz A/D with DDC, Kintex UltraScale FPGA) has the following variants:

Model	
52141A	3U VPX board (single XMC)
54141A	3U VPX board (single XMC with optical/backplane RF)
57141A	6U VPX board (single XMC)
58141A	6U VPX board (dual XMC)
71141A	XMC module
78141A	PCIe board (single XMC)

LIFETIME SUPPORT FOR JADE PRODUCTS

Mercury offers worldwide customers shorter development time, reliable, rugged solutions for a variety of environments, reduced costs, and mature software development tools. We offer free lifetime support from our engineering staff, which customers can depend on through phone and email, as well as software updates. Take advantage of our 40 years of experience in delivering high-performance radar, communications, SIGINT, EW, and data acquisition MIL-Aero solutions worldwide.



Corporate Headquarters

50 Minuteman Road
 Andover, MA 01810 USA
+1 978.967.1401 tel
+1 866.627.6951 tel
+1 978.256.3599 fax

International Headquarters

Mercury International
 Avenue Eugène-Lance, 38
 PO Box 584
 CH-1212 Grand-Lancy 1
 Geneva, Switzerland
+41 22 884 5100 tel

Learn more

Visit: mrcy.com/go/MP52141A

For technical details, contact:
mrcy.com/go/CF52141A



The Mercury Systems logo and the following are trademarks or registered trademarks of Mercury Systems, Inc.: Mercury Systems, Innovation That Matters, Jade and Navigator. Other marks used herein may be trademarks or registered trademarks of their respective holders. Mercury believes this information is accurate as of its publication date and is not responsible for any inadvertent errors. The information contained herein is subject to change without notice.

