

Onyx 52741

1-channel 3.6 GHz or 2-channel 1.8 GHz,
12-bit A/D with wideband DDC
3U VPX board with Virtex-7 FPGA

Complete radar and software radio interface solution

- Radar and software radio receiver
- Communications receiver
- Analog signal interface for data recording
- Wideband data acquisition
- Remote monitoring
- Sensor interfaces



The 52741 is a high-speed data converter with a programmable DDC, suitable for connection to HF or IF ports of a communications or radar system. Its built-in data capture features offer an ideal turnkey solution.

The 52741 includes a 3.6 GHz, 12-bit A/D converter and four banks of memory. In addition to supporting PCI Express Gen. 3 as a native interface, the 52741 includes an optional connection to the Virtex-7 FPGA for custom I/O.

FEATURES

- Supports Xilinx® Virtex®-7 VXT FPGA
- GateXpress® supports dynamic FPGA reconfiguration across PCIe
- One-channel mode with 3.6 GHz, 12-bit A/D
- Two-channel mode with 1.8 GHz, 12-bit A/Ds
- Programmable one- or two-channel DDC (Digital Downconverter)
- 4 GB of DDR3 SDRAM
- µSync clock/sync bus for multiboard synchronization
- PCI Express (Gen. 1, 2 & 3) interface up to x4
- Optional user-configurable gigabit serial interface
- Optional LVDS connections to the Xilinx® Virtex®-7 FPGA for custom I/O
- Compatible with several VITA standards including: VITA-46, VITA-48 and VITA-65 (OpenVPX™ System Specification)

52741 BLOCK DIAGRAMS

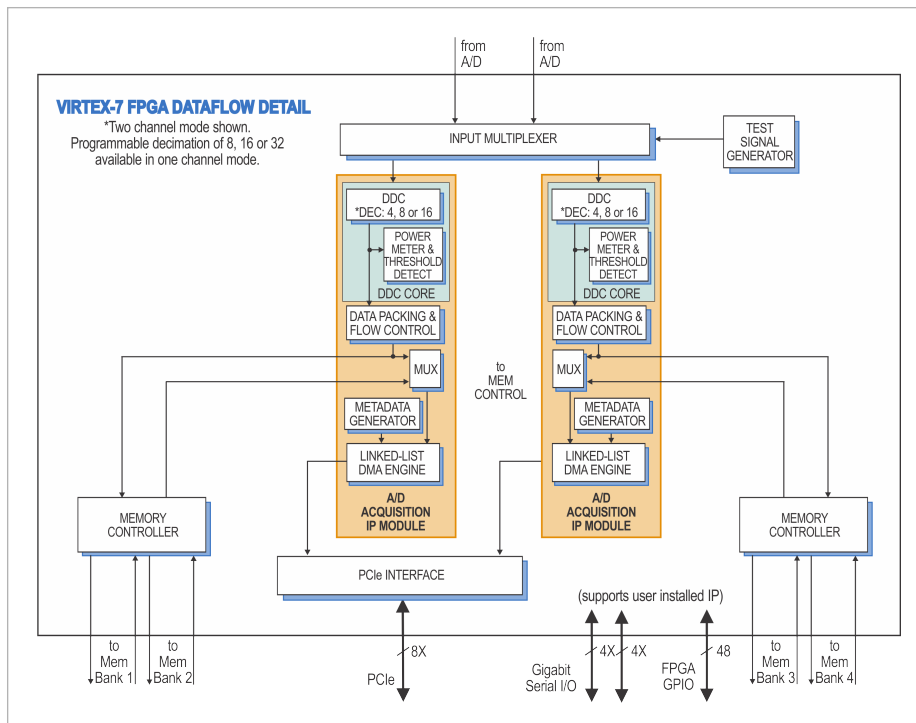
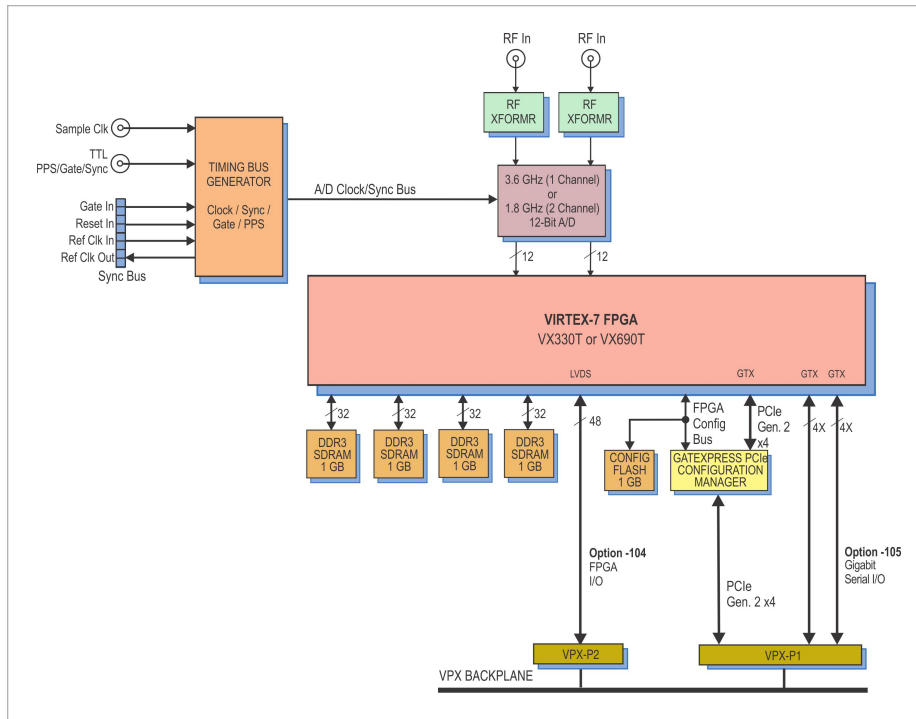

THE ONYX ARCHITECTURE

Based on the proven design of the Mercury Cobalt family, Onyx raises the processing performance with the new flagship family of Virtex-7 FPGAs from Xilinx. As the central feature of the board architecture, the FPGA has access to all data and control paths, enabling factory-installed functions including data multiplexing, channel selection, data packing, gating, triggering and memory control. The Onyx Architecture organizes the FPGA as a container for data processing applications where each function exists as an intellectual property (IP) module.

Each member of the Onyx family is delivered with factory-installed applications ideally matched to the board's analog interfaces. The 52741 factory-installed functions include an A/D acquisition IP module and a programmable digital downconverter. In addition, IP modules for DDR3 SDRAM memories, a controller for all data clocking and synchronization functions, a test signal generator and a PCIe interface complete the factory-installed functions and enable the 52741 to operate as a complete turnkey solution, without the need to develop any FPGA IP.

EXTENDABLE IP DESIGN

For applications that require specialized functions, users can install their own custom IP for data processing. The GateFlow FPGA Design Kits include all of the factory-installed modules as document source code. Developers can integrate their own IP with the factory-installed functions or use the GateFlow kit to completely replace the IP with their own.

XILINX VIRTEX-7 FPGA

The Xilinx Virtex-7 FPGA site can be populated with one of two FPGAs to match the specific requirements of the processing task. Supported FPGAs are VX330T or VX690T. The VX690T features 3600 DSP48E1 slices and is ideal for modulation/demodulation, encoding/decoding, encryption/decryption, and channelization of the signals between transmission and reception. For applications not requiring large DSP resources or logic, the lower-cost VX330T can be installed.

A/D CONVERTER STAGE

The board's analog interface accepts analog HF or IF inputs on a pair of front panel SSMC connectors with transformer coupling into a Texas Instruments ADC12D1800 12-bit A/D. The converter operates in single-channel interleaved mode with a sampling rate of 3.6 GHz and an input bandwidth of 1.75 GHz; or, in dual-channel mode with a sampling rate of 1.8 GHz and input bandwidth of 2.8 GHz.

The ADC12D1800 provides a programmable 15-bit gain adjustment allowing the 71741 to have a full scale input range of +2 dBm to +4 dBm. A built-in AutoSync feature supports A/D synchronization across multiple boards.

The A/D digital outputs are delivered into the Xilinx® Virtex®-7 FPGA for signal processing, data capture or for routing to other board resources.

A/D ACQUISITION IP MODULES

The 52741 features an A/D Acquisition IP Module for easy capture and data moving. The IP module can receive data from the A/D, or a test signal generator. The IP module has associated memory banks for buffering data in FIFO mode or for storing data in transient capture mode. In single-channel mode, all four banks are used to store the single-channel of input data. In dual-channel mode, memory banks 1 and 2 store data from input channel 1 and memory banks 3 and 4 store data from input channel 2. In both modes, continuous, full-rate transient capture of 12-bit data is supported.

The memory banks are supported with a DMA engine for moving A/D data through the PCIe interface. This powerful linked-list DMA engine is capable of a unique Acquisition Gate Driven mode. In this mode, the length of a transfer performed by a link definition need not be known prior to data acquisition; rather, it is governed by the length of the acquisition gate. This is extremely useful in applications where an external gate drives acquisition and the exact length of that gate is not known or is likely to vary.

For each transfer, the DMA engine can automatically construct metadata packets containing a sample-accurate time stamp and data length information. These actions simplify the host processor's job of identifying and executing on the data.

DDC IP CORES

Within the FPGA is a powerful DDC IP core. The core supports a single-channel mode, accepting data samples from the A/D at the full 3.6 GHz rate. Additionally, a dual-channel mode supports the A/Ds 1.8 GHz two-channel operation.

In dual-channel mode, each DDC has an independent 32-bit tuning frequency setting that ranges from DC to f_s , where f_s is the A/D sampling frequency. In single-channel mode, decimation can be programmed to 8x, 16x or 32x. In dual-channel mode, both channels share the same decimation rate, programmable to 4x, 8x or 16x.

In single-channel mode, decimation can be programmed to 8x, 16x or 32x. In dual-channel mode, both channels share the same decimation rate, programmable to 4x, 8x or 16x.

The decimating filter for each DDC accepts a unique set of user-supplied 18-bit coefficients. The 80% default filters deliver an output bandwidth of $0.8 * f_s / N$, where N is the decimation setting. The rejection of adjacent-band components within the 80% output bandwidth is better than 100 dB. Each DDC delivers a complex output stream consisting of 24-bit I + 24-bit Q or 16-bit I + 16-bit Q samples at a rate of f_s / N .

CLOCKING AND SYNCHRONIZATION

The 52741 accepts a 1.8 GHz dual-edge sample clock via a front panel SSMC connector. A second front panel SSMC accepts a TTL signal that can function as Gate, PPS or Sync.

A front panel μ Sync bus connector allows multiple boards to be synchronized, ideal for multichannel systems. The μ Sync bus includes gate, reset, and in and out reference clock signals. Two 52741s can be synchronized with a simple cable. For larger systems, multiple 52741s can be synchronized using the Model 5292 high-speed sync board to drive the sync bus.

MEMORY RESOURCES

The 52741 architecture supports four independent DDR3 SDRAM memory banks. Each bank is 1 GB deep and is an integral part of the module's DMA capabilities, providing FIFO memory space for creating DMA packets. Built-in memory functions include multichannel A/D data capture, tagging and streaming.

PCI EXPRESS INTERFACE

The Model 52741 includes an industry-standard interface fully compliant with PCI Express Gen. 1, 2 and 3 bus specifications. Supporting PCIe links up to x8, the interface includes multiple DMA controllers for efficient transfers to and from the board.

GATEXPRESS FOR FPGA CONFIGURATION

The Onyx architecture includes GateXpress[®], a sophisticated FPGA-PCIe configuration manager for loading and reloading the FPGA. At power up, GateXpress immediately presents a PCIe target for the host computer to discover, effectively giving the FPGA time to load from FLASH. This is especially important for larger FPGAs where the loading times can exceed the PCIe discovery window, typically 100 msec on most PCs.

The board's configuration FLASH can hold four FPGA images. Images can be factory-installed IP or custom IP created by the user, and programmed into the FLASH via JTAG using Xilinx iMPACT or through the board's PCIe interface. At power up the user can choose which image will load based on a hardware switch setting. Once booted, GateXpress allows the user three options for dynamically reconfiguring the FPGA with a new IP image:

- The first is the option to load an alternate image from FLASH through software control. The user selects the desired image and issues a reload command.
- The second option is for applications where the FPGA image must be loaded directly through the PCIe interface. This is important in security situations where there can be no latent user image left in nonvolatile memory when power is removed. In applications where the FPGA IP may need to change many times during the course of a mission, images can be stored on the host computer and loaded through PCIe as needed.
- The third option, typically used during development, allows the user to directly load the FPGA through JTAG using Xilinx iMPACT.

In all three FPGA loading scenarios, GateXpress handles the hardware negotiation simplifying and streamlining the loading task. In addition, GateXpress preserves the PCIe configuration space allowing dynamic FPGA reconfiguration without a host computer reset to rediscover the board. After the reload, the host simply continues to see the board with the expected device ID.

READYFLOW

Mercury provides ReadyFlow[®] BSPs (Board Support Packages) for all Cobalt, Onyx, and Flexor products. Available for both Linux and Windows, these packages:

- Provide a path for quick start-up through application completion
- Allow programming at high, intermediate and low levels to meet various needs
- Are illustrated with numerous examples
- Include complete documentation and definitions of all functions
- Include library and example source code.

ReadyFlow BSPs contain C-language examples that can be used to demonstrate the capabilities of Cobalt, Onyx, and Flexor products. These programming examples will help you get an immediate start on writing your own application. They provide sample code that is known to work, giving you a means of verifying that your board set is operational.

COMMAND LINE INTERFACE

The Command Line Interface provides access to pre-compiled executable examples that operate the hardware right out of the box, without the need to write any code. Board-specific hardware

operating arguments can be entered in the command line to control parameters: number of channels to enable, sample clock frequency, data transfer size, reference clock frequency, reference clock source, etc.

The Command Line Interface can be used to call an example application from within a larger user application to control the hardware, and parameter arguments are passed to the application for execution. Functions that control data acquisition automatically save captured data to a pre-named host file or are routed to the Signal Analyzer example function for display.

SIGNAL ANALYZER

When used with the Command Line Interface, the Signal Analyzer allows users to immediately start acquiring and displaying A/D data. A full-featured analysis tool, the Signal Analyzer displays data in time and frequency domains. Built-in measurement functions display 2nd and 3rd harmonics, THD, and SINAD. Interactive cursors allow users to mark data points and instantly calculate amplitude and frequency of displayed signals.

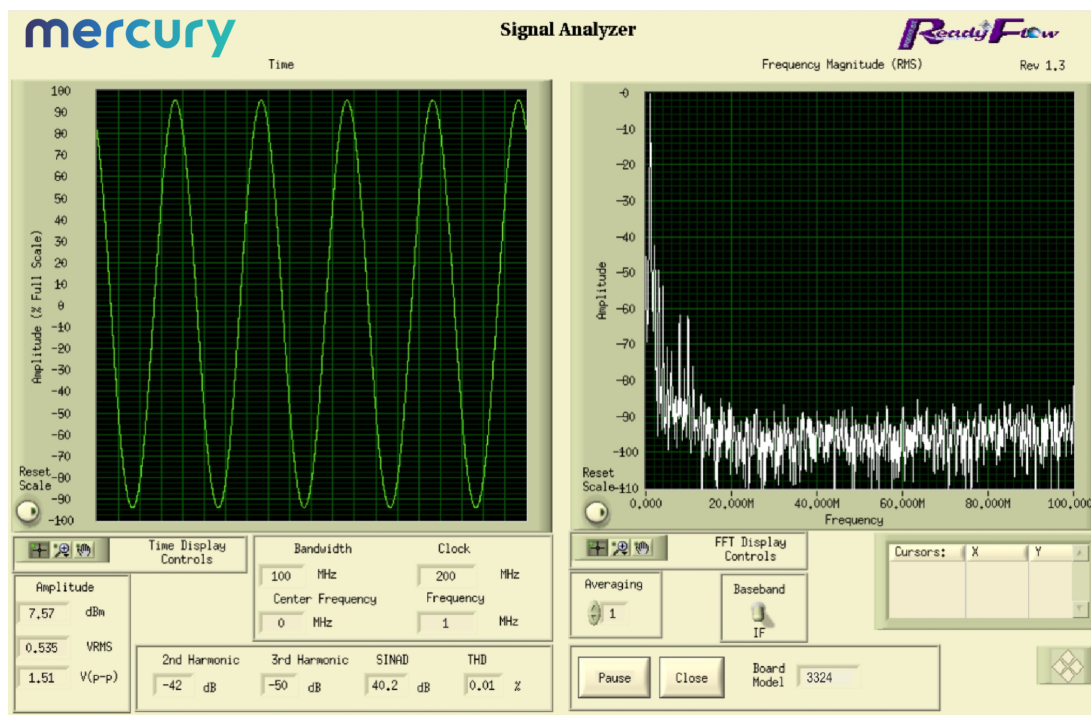

GATEFLOW

The GateFlow® FPGA Design Kit (FDK) allows the user to modify, replace and extend the standard installed functions in the FPGA to incorporate special modes of operation, new control structures, and specialized signal-processing algorithms.

The Cobalt (Virtex-6), Onyx (Virtex-7), and Flexor (Virtex-7) architectures configure the FPGA with standard factory-supplied interfaces including memory controllers, DMA engines, A/D and D/A interfaces, timing and synchronization structures, triggering and gating logic, time stamping and header tagging, data formatting engines, and the PCIe interface. These resources are connected to the User Application Container using well-defined ports that present easy-to-use data and control signals, effectively abstracting the lower-level details of the hardware.

The User Application Container

Shown below is the FPGA block diagram of a typical Cobalt, Onyx or Flexor module. The User Application Container holds a collection of different installed IP modules connected to the various interfaces through the standard ports surrounding the container. The specific IP modules for each product are described in further detail in the datasheet of that product.

The GateFlow FDK provides a complete Xilinx's ISE or Vivado project folder containing all the files necessary for the FPGA developer to recompile the entire project with or without any required changes. VHDL source code for each IP module provides excellent examples of how the IP modules work, how they might be modified, and how they might be replaced with custom IP to implement a specific function.

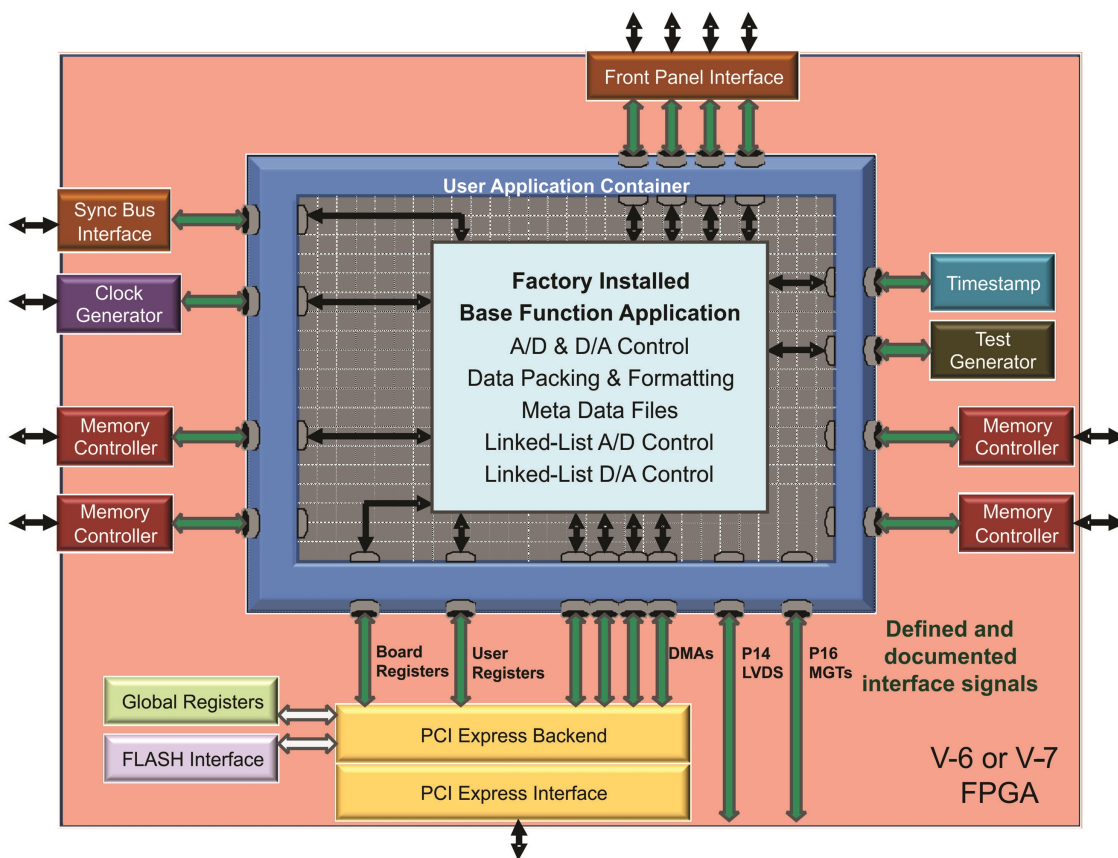

FRONT PANEL CONNECTIONS

The XMC front panel includes four SSMC coaxial connectors and a 19-pin Sync Bus connector for input/output of timing and analog signals. The front panel also includes five LEDs.

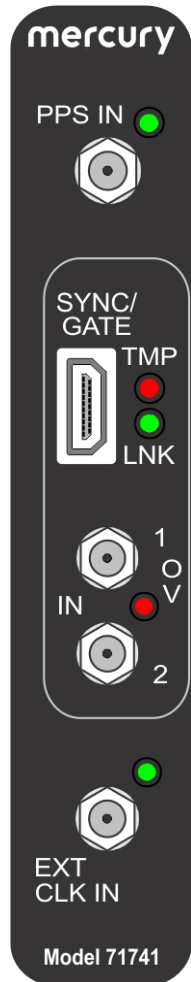

- **PPS LED:** The green **PPS** LED illuminates when a valid PPS signal is detected. The LED will blink at the rate of the PPS signal.
- **PPS Input Connector:** The SSMC coaxial connector, labeled **PPS IN** is for input of an external PPS or Gate signal.
- **Sync Bus Connector:** The 19-pin Sync Bus front panel connector, labeled **SYNC/GATE**, provides clock, sync, and gate input/output pins for the Sync Bus.
- **Over Temperature LED:** The red **TMP** LED illuminates when an over-temperature or over-voltage condition is indicated by any of the temperature/voltage sensors on the PCB.
- **Link LED:** The green **LNK** LED blinks when a valid link has been established over the PCIe interface.
- **Analog Input Connectors:** Two SSMC coaxial connectors, labeled **IN 1** and **IN 2** are for each ADC12D1800 input channel.
- **A/D Overload LED:** There is one red **OV** (overload) LED for the A/D input. It

indicates either an analog input overload in the associated ADC12D1800, or an ADC FIFO overrun.

- **Clock LED:** The green **CLK** LED illuminates when a valid sample clock signal is detected. If the LED is not illuminated, no clock has been detected and no data from the input stream can be processed.
- **Clock Input Connector:** One SSMC coaxial connector, labeled **EXT CLK IN**, for input of an external sample clock.

SPECIFICATIONS

Front Panel Analog Signal Inputs

Input Type: Transformer-coupled, front panel female SSMC connectors

A/D Converter

Type: Texas Instruments ADC12D1800

Sampling Rate: Single-channel mode: 500 MHz to 3.6 GHz; dual-channel mode: 150 MHz to 1.8 GHz

Resolution: 12 bits

Input Bandwidth: single-channel mode: 1.75 GHz; dual-channel mode: 2.8 GHz

Full Scale Input: +2 dBm to +4 dBm, programmable

Digital Downconverters

Modes: One or two channels, programmable

Supported Sample Rate: One-channel mode: 3.6 GHz, two-channel mode: 1.8 GHz

Decimation Range: One-channel mode: 8x, 16x or 32x, two-channel mode: 4x, 8x, or 16x

LO Tuning Freq. Resolution: 32 bits, 0 to f_s

LO SFDR: >120 dB

Phase Offset Resolution: 32 bits, 0 to 360 degrees

FIR Filter: User-programmable 18-bit coefficients

Default Filter Set: 80% bandwidth, <0.3 dB passband ripple, >100 dB stopband attenuation

Sample Clock Source

Front panel SSMC connector

Timing Bus

19-pin μ Sync bus connector includes sync and gate/trigger inputs, CML

External Trigger Input

Type: Front panel female SSMC connector, LVTTTL

Function: Programmable functions include: trigger, gate, sync and PPS

Field Programmable Gate Array

- Standard: Xilinx Virtex-7 XC7VX330T-2
- Optional: Xilinx Virtex-7 XC7VX690T-2

Custom I/O

- Option -104: Provides 20 pairs of LVDS connections between the FPGA and the VPX P2 connector for custom I/O
- Option -105: Provides one 8X or two 4X gigabit links between the FPGA and the VPX P1 connector to support serial protocols

Memory

Type: DDR3 SDRAM
 Size: Four banks, 1 GB each
 Speed: 800 MHz (1600 MHz DDR)

PCI-Express Interface

PCI Express Bus: Gen. 1, 2 or 3: x4

Environmental

Standard: L0 (air-cooled)

- Operating Temp: 0° to 50° C
- Storage Temp: -20° to 90° C
- Relative Humidity: 0 to 95%, non-condensing

Option -702: L2 (air-cooled)

- Operating Temp: -20° to 65° C
- Storage Temp: -40° to 100° C
- Relative Humidity: 0 to 95%, non-condensing

Option -763: L3 (conduction-cooled)

- Operating Temp: -40° to 70° C
- Storage Temp: -50° to 100° C
- Relative Humidity: 0 to 95%, non-condensing

Physical

Dimensions: Form Factor: 3U VPX

- Depth: 170.6 mm (6.717 in.)
- Height: 100 mm (3.937 in.)

Weight

- VPX Carrier: 110 grams (3.9 oz.);
- XMC Module: approximately 400 grams (14 oz.) with 2-slot heatsink

ORDERING INFORMATION

Model	Description
52741	1-Ch. 3.6 GHz or 2-Ch. 1.8 GHz, 12-bit A/D with Wideband DDC, Virtex-7 FPGA - 3U VPX

Options	Description
-073	XC7VX330T-2 FPGA
-076	XC7VX690T-2 FPGA
-104	LVDS FPGA I/O to VPX P2
-105	Gigabit serial FPGA I/O to VPX P1
-702	Air-cooled, Level 2
-763	Conduction-cooled, Level 3
Contact Mercury for compatible option combinations.	

ACCESSORY PRODUCTS

Model	Description
5292	High-Speed Synchronizer and Distribution Board
9192	Rackmount High-Speed System Synchronizer
5294	High-Speed Clock Generator

DEVELOPMENT SYSTEMS

Mercury offers development systems for Onyx products. They come with all pre-tested software and hardware ready for immediate operation. These systems are intended to save engineers and system integrators the time and expense associated with building and testing a development system that ensures optimum performance of Onyx boards. Please [contact Mercury](#) to configure a system that matches your requirements.

FORM FACTORS

Onyx products are available in standard form factors including 3U VPX, 6U VPX, PCIe, and XMC. The Onyx Model 71741 XMC (1-Channel 3.6 GHz or 2-Channel 1.8 GHz 12-bit A/D with DDC with Virtex-7 FPGA) has the following variants:

Model	
52741	3U VPX board (single XMC)
57741	6U VPX board (single XMC)
58741	6U VPX board (dual XMC)
71741	XMC module
78741	PCIe board (single XMC)

LIFETIME SUPPORT FOR ONYX PRODUCTS

Mercury offers worldwide customers shorter development time, reliable, rugged solutions for a variety of environments, reduced costs, and mature software development tools. We offer free lifetime support from our engineering staff, which customers can depend on through phone and email, as well as software updates. Take advantage of our 40 years of experience in delivering high-performance radar, communications, SIGINT, EW, and data acquisition MIL-Aero solutions worldwide.



Corporate Headquarters

50 Minuteman Road
 Andover, MA 01810 USA
+1 978.967.1401 tel
+1 866.627.6951 tel
+1 978.256.3599 fax

International Headquarters

Mercury International
 Avenue Eugène-Lance, 38
 PO Box 584
 CH-1212 Grand-Lancy 1
 Geneva, Switzerland
+41 22 884 5100 tel

Learn more

Visit: mrcy.com/go/MP52741

For technical details, contact:
mrcy.com/go/CF52741



The Mercury Systems logo and the following are trademarks or registered trademarks of Mercury Systems, Inc.: Mercury Systems, Innovation That Matters, Cobalt, Flexor, Onyx, GateXpress, GateFlow, and ReadyFlow. Other marks used herein may be trademarks or registered trademarks of their respective holders. Mercury believes this information is accurate as of its publication date and is not responsible for any inadvertent errors. The information contained herein is subject to change without notice.

