

Flexor 5983-324

4-channel 500 MHz 16-bit A/D, 4-channel 2 GHz 16-bit D/A
3U VPX board with Kintex Ultrascale FPGA

Complete radar and software radio interface solution

- Radar and communication receiver and transmitter
- Electronic Warfare transponder
- Waveform signal generator
- Wideband data acquisition
- Remote monitoring
- Sensor interfaces



Model 5983 is a member of the Flexor® family of high-performance 3U VPX baseboards with a Xilinx Kintex UltraScale FPGA and an available FMC I/O slot. As an integrated solution, the Model 5983-324 FlexorSet® combines the Model 5983 and the Model 3324 Flexor® FMC as a factory-installed set. The required FPGA IP is installed and the board set is delivered ready for immediate use.

The delivered FlexorSet is a multichannel, high-speed data converter with programmable DDCs (Digital Downconverters) and is suitable for connection to the HF or IF ports of a communications or radar system. Its built-in data capture features offer an ideal turnkey solution as well as a platform for developing and deploying custom FPGA processing IP.

In addition to the Gen. 3 x8 PCIe interface, the 5983 architecture includes an optional built-in gigabit serial optical interface. Up to 12 high-speed duplex optical lanes are available on a VITA-66.4 connector. With the installation of a serial protocol in the FPGA, this interface enables a high-bandwidth connection between 5983's mounted in the same chassis or even over extended distances.

FEATURES

- Supports Xilinx® Virtex®-7 VXT FPGA
- Four 500 MHz, 16-bit A/Ds
- Four DUCs (digital upconverters)
- Four 2 GHz, 16-bit D/As (500 MHz input data rate, 2 GHz output sample rate with interpolation)
- 4 and 5 GB of DDR3 SDRAM
- Sample clock synchronization to [an external system reference](#)
- PCI Express (Gen. 1, 2 & 3) interface up to x8
- User-configurable gigabit serial interface
- Optional optical interface for gigabit serial interboard communication
- LVDS connections to the Kintex Ultrascale FPGA for custom I/O and synchronization
- Compatible with several VITA standards including: VITA-46, VITA-48, VITA-66.4 and VITA-65 (Open VPX™ System Specification)
- Ruggedized and conduction-cooled versions available
- Navigator® BSP for software development
- Navigator® FDK for custom IP development
- Free lifetime applications support

THE FLEXOR ARCHITECTURE

Based on the proven design of the Mercury Jade family of Kintex products, the 5983 FMC carrier retains all the key features of that family. As a central foundation of the board architecture, the FPGA has access to all data and control paths of both the carrier board and the FMC module, enabling factory-installed functions that include data multiplexing, channel selection, data packing, gating, triggering and memory control.

When delivered as an assembled board set, the 5983-324 includes factory-installed applications ideally matched to the board's analog interfaces. The functions include two A/D acquisition IP modules for simplifying data capture and data transfer.

The 5983-324 features a sophisticated D/A waveform generator IP module. A linked-list controller allows users to easily record to the D/As waveforms stored in either on-board or off-board host memory. Parameters including length of waveform, delay from trigger, waveform repetition, etc. can be programmed for each waveform.

Up to 64 individual link entries can be chained together to create complex waveforms with a minimum of programming.

A controller for all data clocking and synchronization functions, a test signal generator, and a PCIe interface complete the factory-installed functions and enable the 5983-324 to operate as a turnkey solution without the need to develop any FPGA IP.

EXTENDABLE IP DESIGN

For applications that require specialized functions, users can install their own custom IP for data processing. The Mercury Navigator® FPGA Design Kits include the board's entire FPGA design as a block diagram that can be edited in Xilinx's Vivado® tool suite. In addition, all source code and complete IP core documentation is included. Developers can integrate their own IP along with the Mercury factory-installed functions or use the Navigator kit to completely replace the Mercury IP with their own.

A controller for all data clocking and synchronization functions, a test signal generator, and a PCIe interface complete the factory-installed functions and enable the 5983-324 to operate as a turnkey solution without the need to develop any FPGA IP.

XILINX VIRTEX-7 FPGA

The 5983-324 can be optionally populated with one of two Kintex UltraScale FPGAs to match the specific requirements of the processing task. Supported FPGAs are KU060 or KU115. The KU115 features 5520 DSP48E2 slices and is ideal for modulation/demodulation, encoding/decoding, encryption/decryption, and channelization of the signals between transmission and reception. For applications not requiring large DSP resources or logic, the lower-cost KU060 can be installed.

Sixteen pairs of LVDS connections are provided between the FPGA and the VPX P2 connector for custom I/O. For applications requiring custom gigabit links, a 4X connection is supported between the FPGA and the VPX P1 connector to support serial protocols.

5983-324 BLOCK DIAGRAM

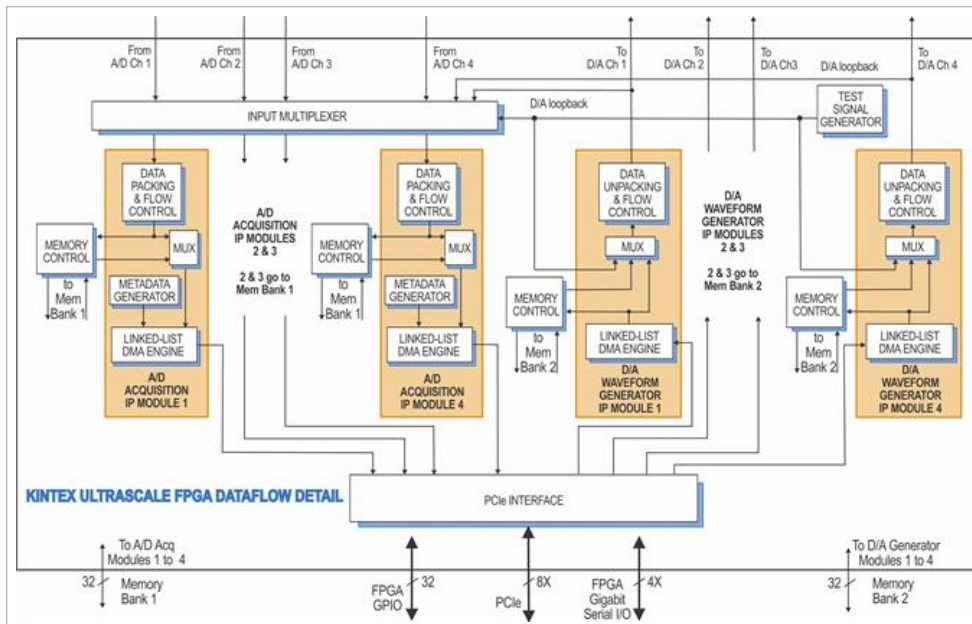
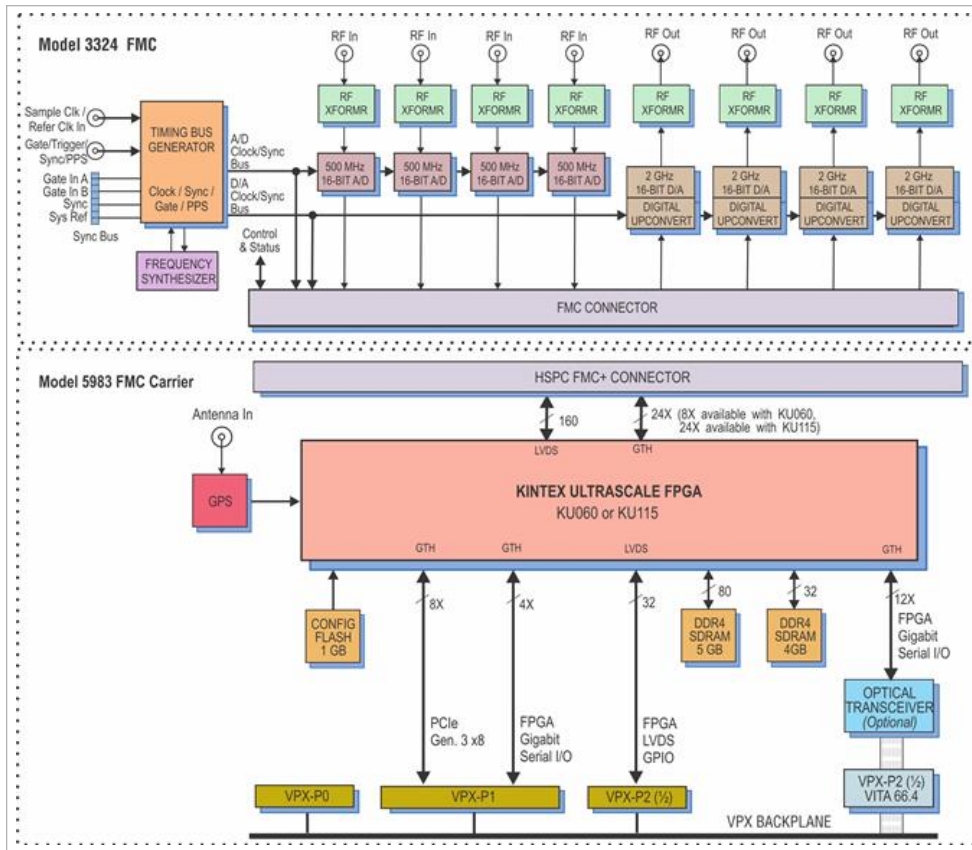

A/D CONVERTER AND DOWNCONVERTER

The board's analog interface accepts four analog RF or IF inputs on front-panel connectors with transformer-coupling into Texas Instruments ADC32RF45 dual channel A/D. With dual built-in digital downconverters and programmable decimations, the converter serves as an ideal interface for a range of radar, signal intelligence and electronic countermeasures applications. The ADC32RF45 can operate within a range of different conversion speeds and resolutions. See the table on the last page for supported modes.

A/D ACQUISITION IP MODULES

The 5983-324 features four A/D Acquisition IP Modules for easy capture and data moving. Each IP module can receive data from any of the four A/Ds, a test signal generator or from the four D/A Waveform Recorder IP modules in loopback mode.

Each IP module has an associated memory bank for buffering data in FIFO mode or for storing data in transient capture mode. All memory banks are supported with DMA engines for moving A/D data through the PCIe interface.

These powerful linked-list DMA engines are capable of a unique Acquisition Gate Driven mode. In this mode, the length of a transfer performed by a link definition need not be known prior to data acquisition; rather, it is governed by the length of the acquisition gate. This is extremely useful in applications where an external gate drives acquisition and the exact length of that gate is not known or is likely to vary.

For each transfer, the DMA engine can automatically construct metadata packets containing A/D channel ID, a sample accurate time stamp, and data length information. These actions simplify the host processor's job of identifying and executing on the data.

D/A WAVEFORM RECORDER IP MODULES

The 5983-324 factory-installed functions include four sophisticated D/A Waveform Recorder IP modules. A linked-list controller allows users to easily record waveforms stored in either on-board or off-board host memory to the four D/As.

Parameters including length of waveform, delay from trigger, waveform repetition, etc. can be programmed for each waveform. Up to 64 individual link entries per module can be chained together to create complex waveforms with a minimum of programming.

DIGITAL UPCONVERTER AND D/A STAGE

Four D/As accept baseband real or complex data streams from the FPGA. Each stream then passes through the upconvert, interpolate and D/A stages of the converter.

When operating as DUCs (digital upconverters), the converters interpolate and translate real or complex baseband input signals to a programmable IF center frequency.

CLOCKING AND SYNCHRONIZATION

Two internal timing buses provide all timing and synchronization required by the A/D and D/A converters. Each includes a clock, sync and gate or trigger signals. An on-board clock generator receives an external sample clock from the front panel coaxial connector.

This clock can be used directly by the A/D or D/A sections or divided by a built-in clock synthesizer circuit to provide different A/D and D/A clocks. In an alternate mode, the sample clock can be sourced from an on-board programmable VCXO. In this mode, the front-panel coaxial connector can be used to provide a 10 MHz reference clock for synchronizing the internal oscillator.

A front panel LVTTTL Gate/Trigger/Sync connector can receive an external timing signal to synchronize multiple modules.

MEMORY RESOURCES

The 5983-324 architecture supports two independent DDR3 SDRAM memory banks. The banks are four and five gigabytes each and are part of the board's DMA capabilities, providing FIFO memory space for creating DMA packets.

PCI EXPRESS INTERFACE

The Model 5983-324 includes an industry standard interface fully compliant with PCI Express Gen. 1, 2, and 3 bus specifications. Supporting PCIe links up to x8, the interface includes multiple DMA controllers for efficient transfers to and from the module.

GPS

An optional GPS receiver provides time and position information to the FPGA. This information can be used for precise data tagging.

NAVIGATOR DESIGN SUITE

For applications that require specialized functions, the Navigator Design Suite allows customers to fully utilize the processing power of the FPGA. It includes an FPGA design kit for integrating custom IP into the factory-shipped design, and a board support package for creating host applications for control of all hardware and FPGA IP-based functions.

The Navigator FPGA Design Kit (FDK) for the Xilinx® Vivado® Design Suite includes the complete Vivado project folder for each Jade product with all design files for the factory-installed FPGA IP. Vivado’s IP Integrator is a graphical design entry tool that visually presents the complete block diagram of all IP blocks so the developer can access every component of the Jade design. Developers can quickly import, delete, and modify IP blocks and change interconnection paths using simple mouse operations.

Navigator FDK includes an IP core library of more than 100 functions representing a wealth of resources for DSP, data formatting, timing, and streaming operations, all based on the powerful AXI4 standard. multilevel documentation for each IP core is a mouse click away, and fully consistent with Xilinx IP cores.

The **Navigator Board Support Package (BSP)** provides software support for Jade boards. It enables operational control of all hardware functions on the board and IP functions in the FPGA. The BSP structure is designed to complement the functions of the FDK by maintaining a one-to-one relationship between FDK and BSP components. For each IP block found in the FDK library, a matching software module can be found in the BSP. This organization simplifies the creation and editing of software to support new IP functions and modifications to existing IP cores.

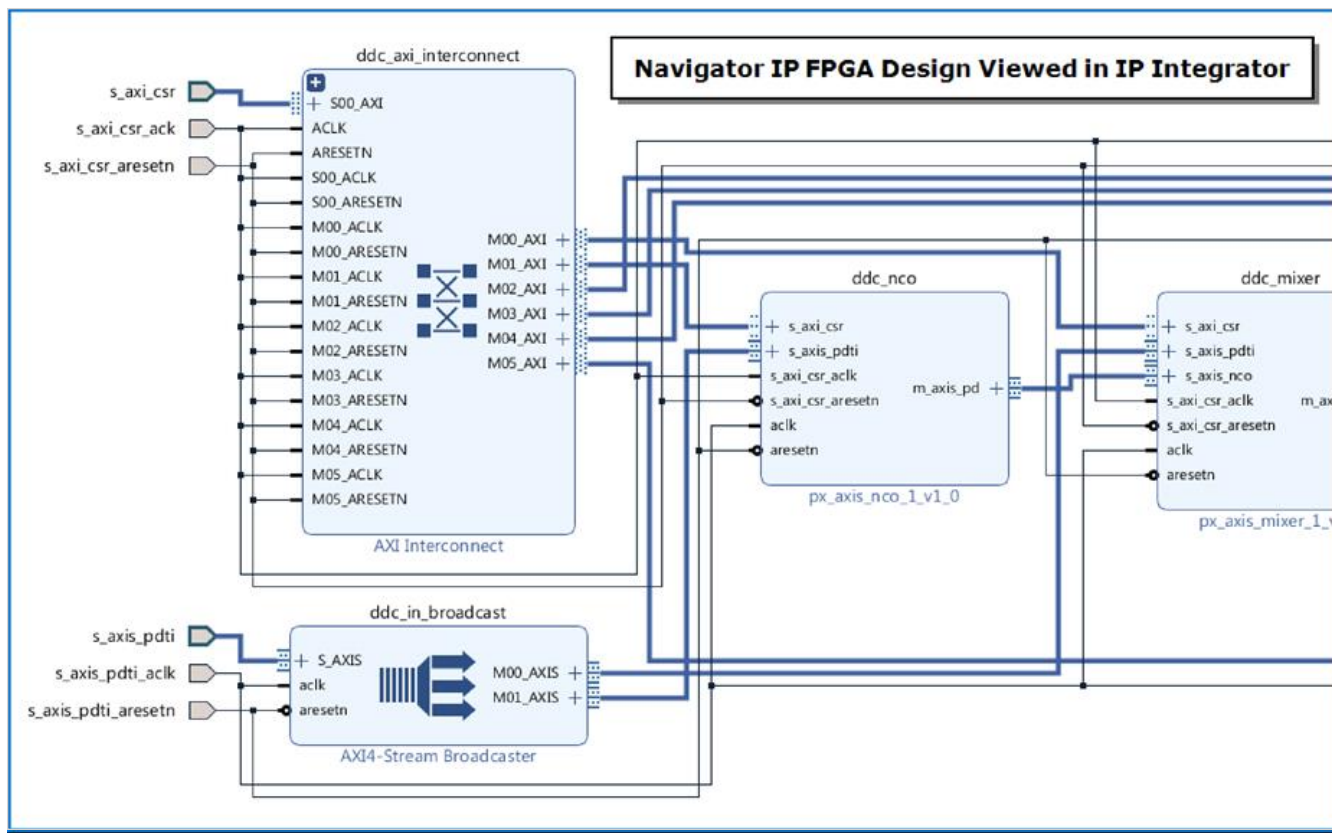

Navigator IP FPGA Design viewed in IP Integrator

NAVIGATOR BOARD SUPPORT PACKAGE

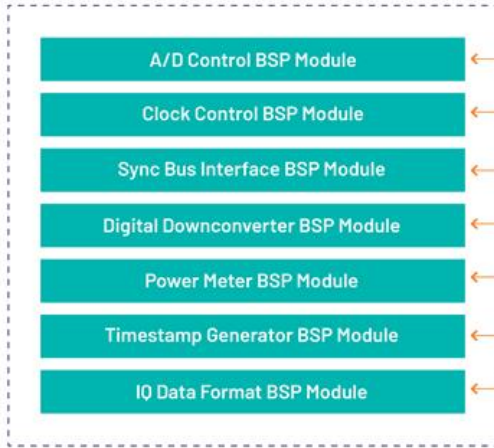

NAVIGATOR FPGA DESIGN KIT

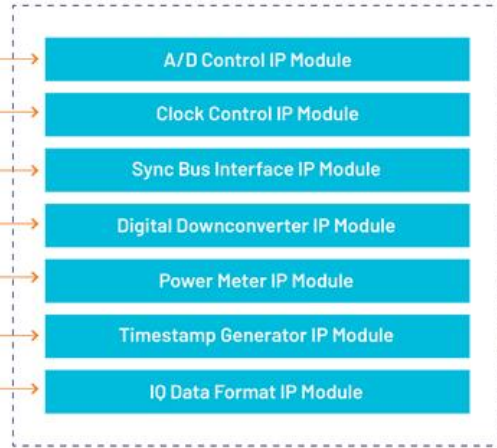

Because all Jade boards are shipped with a full suite of built-in IP functions and numerous software examples, new applications can be developed by building on the provided software examples or built entirely new with the BSP extensive libraries. All BSP libraries are provided as C-language source for full access and code transparency.

The Navigator BSP includes the **Signal Viewer**, a full-featured analysis tool, that displays data in time and frequency domains. Built-in measurement functions display 2nd and 3rd harmonics, THD (total harmonic distortion), and SINAD (signal to noise and distortion). Interactive cursors allow users to mark data points and instantly calculate amplitude and frequency of displayed signals. With the Signal Viewer users can install the Jade board and Navigator BSP and start viewing analog signals immediately.

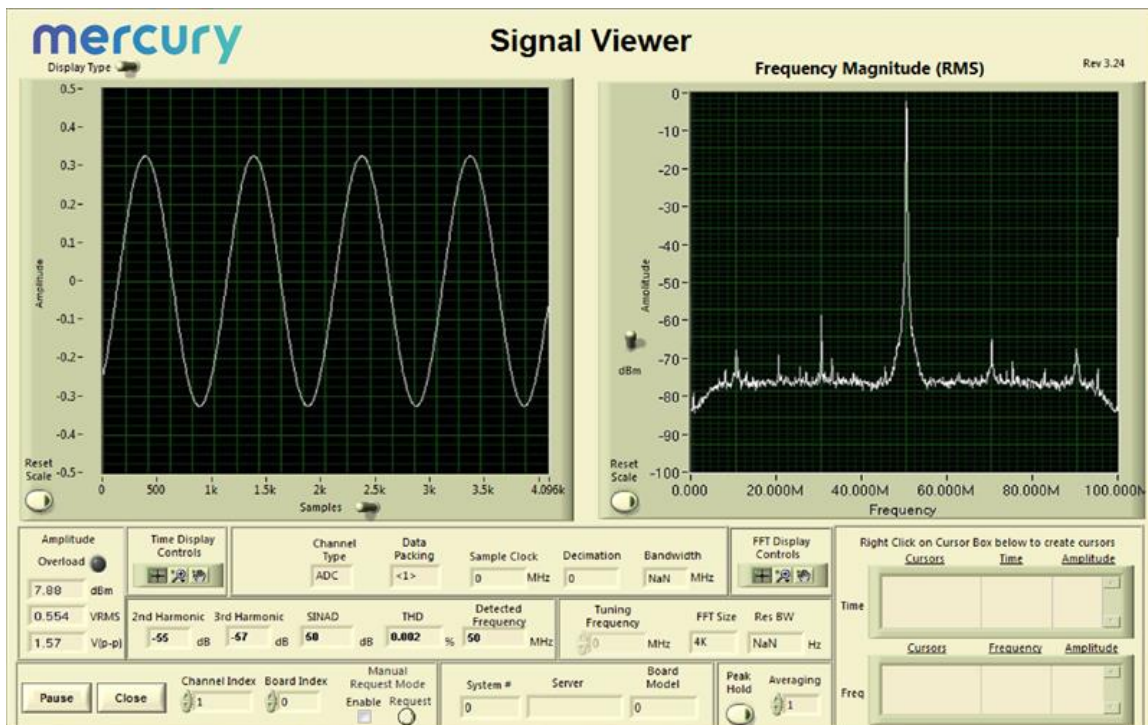

FRONT PANEL CONNECTIONS

The FMC front panel includes ten SSMC coaxial connectors, and a 19-pin µSync connector for input/output of timing and analog signals. The front panel also includes four LEDs.



- **Analog Input Connectors:** Four coaxial connectors labeled **ADC IN 1, 2, 3, and 4** one for each ADC input channel. **IN 1 and 2** are input to the first ADS54J60 and **IN 3 and 4** are input to the second ADS54J60.
- **ADC Overload LEDs:** The red **OV** (overload) LED indicates either an overload in the associated ADS54J60 or an ADC FIFO overrun.
- **User LED:** The green **USR** LED is for user applications.
- **Analog Output Connectors:** Four coaxial connectors, labeled **DAC OUT 1, 2, 3, and 4** for each DAC38J84 output.
- **Clock LED:** The green **EXT CLK IN** LED illuminates when a valid sample clock signal is detected. If the LED is not illuminated, no clock has been detected and no data from the input stream can be processed.
- **Over Temperature LED:** The red **TMP** LED illuminates when an over-temperature or over-voltage condition is indicated by any of the temperature/voltage sensors on the PCB.
- **Trigger Input Connector:** One coaxial connector labeled **TRG** for input of an external trigger.
- **Sync Bus Connector:** The 19-pin Sync Bus front panel connectors labeled **SYNC/GATE** provides sync and gate input signals for the Sync Bus.

FRONT PANEL CONNECTIONS

The 5983 3U VPX carrier front panel houses the front panel of the FMC installed on the carrier. The carrier front panel includes a reset button, two or four MMCX coaxial connectors, a JTAG connector, and three LED indicators



- **Reset Button:** The white reset button, labeled **RST**, provides a reset and safe reboot of the onboard GPS receiver (Option 180).
- **VPX Clock Connector:** The MMCX connector labeled **VPX CLK** provides output of the 100-MHz PCI clock from the VPX P0 connector (see VPX P0 Utility Connector).
- **10 MHz Reference Connector:** With Option 180, the MMCX connector labeled **REF OUT** provides output of the 10-MHz PCI clock from the onboard GPS receiver.
- **GPS Antenna Connector:** With Option 180, the front panel has one MMCX connector, labeled **GPS ANT**, for input of an antenna RF signal for the onboard GPS receiver. The antenna input signal has a sensitivity of +2 dBm to -167 dBm into 50W input impedance.
- **PPS Connector:** The MMCX connector labeled **PPS** provides output of a PPS signal that can be derived from the onboard GPS receiver (Option 180).
- **PCIe Link LED:** The green **PCIE LNK** LED illuminates when a valid PCIe link has been established over the VPX interface.
- **JTAG Connector:** The carrier front panel provides a 12-pin JTAG connector to download programs and to perform boundary-scan tests on the devices.
- **Over Temperature LED:** The red **TEMP** LED illuminates when an over-temperature or over-voltage condition is indicated by the temperature/voltage sensors.
- **User LED:** The yellow **FPGA USR** LED is available for user applications.

Note: If your 5983 is ordered with Option 763 for mounting in a conduction-cooled VPX chassis, it would have a conduction-cooled VPX Carrier Front Panel.

SPECIFICATIONS

Front Panel Analog Signal Inputs

Input Type: Transformer-coupled, front panel connectors

Transformer Type: Coil Craft WBC1-1TLB

Full Scale Input: +4 dBm into 50 ohms

3 dB Passband: 300 kHz to 750 MHz

A/D Converters

Type: Texas Instruments ADS54J60

Sampling Rate: Up to 500 MHz

Resolution: 16 bits

Front Panel Analog Signal Outputs

Output Type: Transformer-coupled, front panel connectors

Transformer Type: Coil Craft WBC4-6TLB

Full-Scale Output: +4 dBm into 50 ohms

3 dB Passband: 300 kHz to 700 MHz

D/A Converters

Type: Texas Instruments DAC38J84

Input Data Rate: Up to 500 MHz

Output Sample Rate: Up to 2 GHz (with interpolation)

Resolution: 16 bits

Sample Clock Sources

On-board clock synthesizer generates two clocks: an A/D clock and a D/A clock

Clock Synthesizer

Clock Source: Selectable from on-board programmable VCXO (10 to 810 MHz), front panel external clock or LVPECL timing bus

Synchronization: VCXO can be locked to an external 4 to 180 MHz PLL system reference, typically 10 MHz

Clock Dividers: External clock or VCXO can be divided by 1, 2, 4, 8 or 16 for the A/D and D/A clocks

External Clock

Type: Front panel connector, sine wave, 0 to +10 dBm, AC-coupled, 50 ohms, accepts 10 to 800 MHz divider input clock or PLL system reference

External Trigger Input

Type: Front panel connector

Function: Programmable functions include: trigger, gate, sync and PPS

Field Programmable Gate Array

- Standard: Xilinx Kintex UltraScale XCKU060-2
- Optional: Xilinx Kintex UltraScale XCKU115-2

Custom FPGA I/O

Serial: 4X gigabit links between the FPGA and the VPX P1 connector to support serial protocols.

Parallel: 16 pairs of LVDS connections are provided between the FPGA and the VPX P2 connector for custom I/O

Optical (Option -110): VITA-66.4, 12X duplex lanes

Memory

Type: DDR3 SDRAM

Size: Two banks, one 4 GB and one 5 GB

Speed: 1200 MHz (2400 MHz DDR)

PCI-Express Interface

PCI Express Bus: Gen. 1, 2 or 3: x4 or x8

Environmental

Standard: L0 (air-cooled)

- Operating Temp: 0° to 50° C
- Storage Temp: -20° to 90° C
- Relative Humidity: 0 to 95%, non-condensing

Option -702: L2 (air-cooled)

- Operating Temp: -20° to 65° C
- Storage Temp: -40° to 100° C
- Relative Humidity: 0 to 95%, non-condensing

Option -763: L3 (conduction-cooled)

- Operating Temp: -40° to 70° C
- Storage Temp: -50° to 100° C
- Relative Humidity: 0 to 95%, non-condensing

Physical

Dimensions: 3U VPX

- Depth: 100 mm (3.937 in)
- Height: 170.6 mm (6.717 in)

OpenVPX Compatibility

The Model 5983-324 is compatible with the following module profile, as defined by the VITA 65 Open-VPX Specification: SLT3-PAY-2F1F2U1E-14.6.6-1.

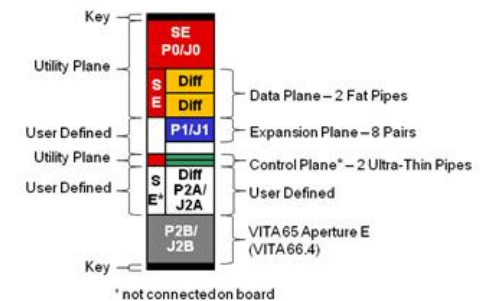

FLEXORSET MODELS

This chart shows all available FlexorSets. Click on model numbers for more information.

Form Factor	Software/FPGA Tools	Carrier Model	FMC Model	FlexorSet Model	Description			
3U VPX	Virtex-7 ReadyFlow BSP GateFlow FDK Vivado	5973	3312	5973-312	4-Channel 250 MHz A/D & 2-Channel 800 MHz D/A			
				5973-313	4-Channel 250 MHz A/D & 2-Channel 800 MHz D/A with 4 multiband DDCs & interpolation filters			
			3316	5973-316	8-Channel 250 MHz 16-bit A/D			
				5973-317	8-Channel 250 MHz 16-bit A/D with 8 multiband DDCs			
			3320	5973-320	2-Channel 3 GHz A/D & 2-Channel 2.8 GHz D/A			
			3324	5973-324	4-Channel 500 MHz A/D & 4-Channel 2 GHz D/A			
	KintexUltraScale Navigator BSP Navigator FDK Vivado	5983*	3312	5983-313*	4-Channel 250 MHz A/D & 2-Channel 800 MHz D/A with 4 multiband DDCs & interpolation filters			
				5983-317*	8-Channel 250 MHz 16-bit A/D with 8 multiband DDCs			
			3320	5983-320*	2-Channel 3 GHz A/D & 2-Channel 2.8 GHz D/A			
			3324	5983-324*	4-Channel 500 MHz A/D & 4-Channel 2 GHz D/A			
			PCIe	Virtex-7 ReadyFlow BSP GateFlow FDK Vivado	7070	3312	7070-312	4-Channel 250 MHz A/D & 2-Channel 800 MHz D/A
							7070-313	4-Channel 250 MHz A/D & 2-Channel 800 MHz D/A with 4 multiband DDCs & interpolation filters
3316	7070-316	8-Channel 250 MHz 16-bit A/D						
	7070-317	8-Channel 250 MHz 16-bit A/D with 8 multiband DDCs						
3320	7070-320	2-Channel 3 GHz A/D & 2-Channel 2.8 GHz D/A						
3324	7070-324	4-Channel 500 MHz A/D & 4-Channel 2 GHz D/A						

*There is a 5983A version of this product. For differences, see below.

Model 5983	Model 5983A
Flash Memory - 1 Gbit of FLASH Memory	Flash Memory -2 Gbit of BPI FLASH Memory
<p>Optical I/O (Option 110) - VITA 66.4 - Up to 12 duplex optical lanes are available on a VITA 66.4 connector.</p> <p>With the installation of a serial protocol, the VITA 66.4 interface enables a high-bandwidth connection between 5983s mounted in the same chassis or over extended distances.</p>	<p>Optical I/O (Option 110) - VITA 67.3D - Provides 12 duplex lanes @ 10 Gb/sec through the lower half of VPX P2 (VPX P2B).</p> <p>With the installation of a serial protocol, the VITA 67.3D interface enables gigabit communications between boards and chassis, independent of the PCIe interface.</p>
	<p>Custom Analog I/O (Option 113) - VITA 67.3 - VITA 67.3 provides 10 coax connections through the lower half of VPX P2.</p>

ORDERING INFORMATION

Model	Description
5983-324	4-Channel 500 MHz 16-bit A/D, 4-Channel 2 GHz 16-bit D/A with Virtex-7 FPGA - 3U VPX

Options:

-087	XCKU115-2 FPGA
-110	VITA-66.4 12X optical interface
-180	GPS support
-702	Air-cooled, Level 2
-763	Conduction-cooled, Level 3

Contact Mercury for compatible option combinations and complete specifications of rugged and conduction-cooled versions. Options may change, so be sure to contact Mercury for the latest information.

ACCESSORY PRODUCTS

Model	Description
2171	Cable kit: SSMC to SMA
5292	High-speed synchronizer and distribution board - 3U VPX model
9192	Rackmount high-speed system synchronizer unit

DEVELOPMENT SYSTEMS

Mercury offers development systems for Flexor products. They come with all pre-tested software and hardware ready for immediate operation. These systems are intended to save engineers and system integrators the time and expense associated with building and testing a development system that ensures optimum performance of Flexor boards. Please contact Mercury to configure a system that matches your requirements.

LIFETIME SUPPORT FOR FLEXOR PRODUCTS

Mercury offers worldwide customers shorter development time, reliable, rugged solutions for a variety of environments, reduced costs, and mature software development tools. We offer free lifetime support from our engineering staff, which customers can depend on through phone and email, as well as software updates. Take advantage of our 40 years of experience in delivering high-performance radar, communications, SIGINT, EW, and data acquisition MIL-Aero solutions worldwide.



Corporate Headquarters

50 Minuteman Road
 Andover, MA 01810 USA
+1 978.967.1401 tel
+1 866.627.6951 tel
+1 978.256.3599 fax

International Headquarters

Mercury International
 Avenue Eugène-Lance, 38
 PO Box 584
 CH-1212 Grand-Lancy 1
 Geneva, Switzerland
+41 22 884 5100 tel

Learn more

Visit: mrcy.com/go/MP5983-324

For technical details, contact:

mrcy.com/CF5983-324



The Mercury Systems logo and the following are trademarks or registered trademarks of Mercury Systems, Inc.: Mercury Systems, Innovation That Matters, Cobalt, Flexor, FlexorSet, GateFlow, ReadyFlow, Onyx, and Navigator. Other marks used herein may be trademarks or registered trademarks of their respective holders. Mercury believes this information is accurate as of its publication date and is not responsible for any inadvertent errors. The information contained herein is subject to change without notice.

