

Model
RTX 2596

Serial FPDP
1/2 ATR

Talon RTX
Extreme Recorder

Small Form
Factor

Features

- **Rugged** 1/2 ATR MIL-spec chassis for harsh mechanical and thermal environments
- **Environmentally sealed**, conduction-cooled
- Fully sealed for RF emissions with EMI power line filter
- MIL-STD circular connectors
- Compact and lightweight: 18 lb (8 kg)
- **QuickPac® drive packs** allow quick removal of all data storage via the front panel
- Ideal for UAVs, military vehicles, aircraft pods, and outdoor environments
- Four-channel Serial FPDP record/playback
- Supports Flow Control, CRC, and Copy/Loop Mode as a receiver and transmitter
- Supports 1.0625, 2.125, 2.5, 3.125, and 4.25 GBaud link rates
- Single-mode and multi-mode fiber interfaces available
- Sustained real-time record rates up to 4 GB/s
- 12 to 28 VDC power supply
- Optional GPS receiver for precise time and position stamping
- **SystemFlow GUI**, **SystemFlow API**, and **Signal Viewer** analysis tools
- Optional **telnet remote connection** to recorder



General Information

Pentek's Talon RTX Small Form Factor (SFF) recorders provide the performance of large rackmount recorders in the smallest footprint available in Pentek's Talon Recording System product line. Housed in an extremely rugged 1/2 ATR form factor, these recorders provide high-performance processing, high speed data storage, and large solid state storage capacity.

Optimized for SWaP (size, weight and power), Talon RTX SFF recorders are packaged in a 1/2 ATR chassis, measuring 7.688" H x 4.880" W x 14.125" D and weighing only 18 pounds (8 kg). These recorders are capable of sustained real-time recording speeds up to 4 GB/s and can hold up to 61 TB of SSD storage. Power consumption has been greatly reduced in this package. A standard system will draw approximately 125 W at full operation.

The Talon RTX 2596 is a small form factor, rugged recorder that is capable of recording and playing back four serial FPDP data streams. The recorder is ideal for capturing any type of streaming source, including live transfers from sensors or data from other computers, and is fully compatible with the VITA 17.1 specification.

RTX 2596 Block Diagram

FRONT PANEL

REAR PANEL

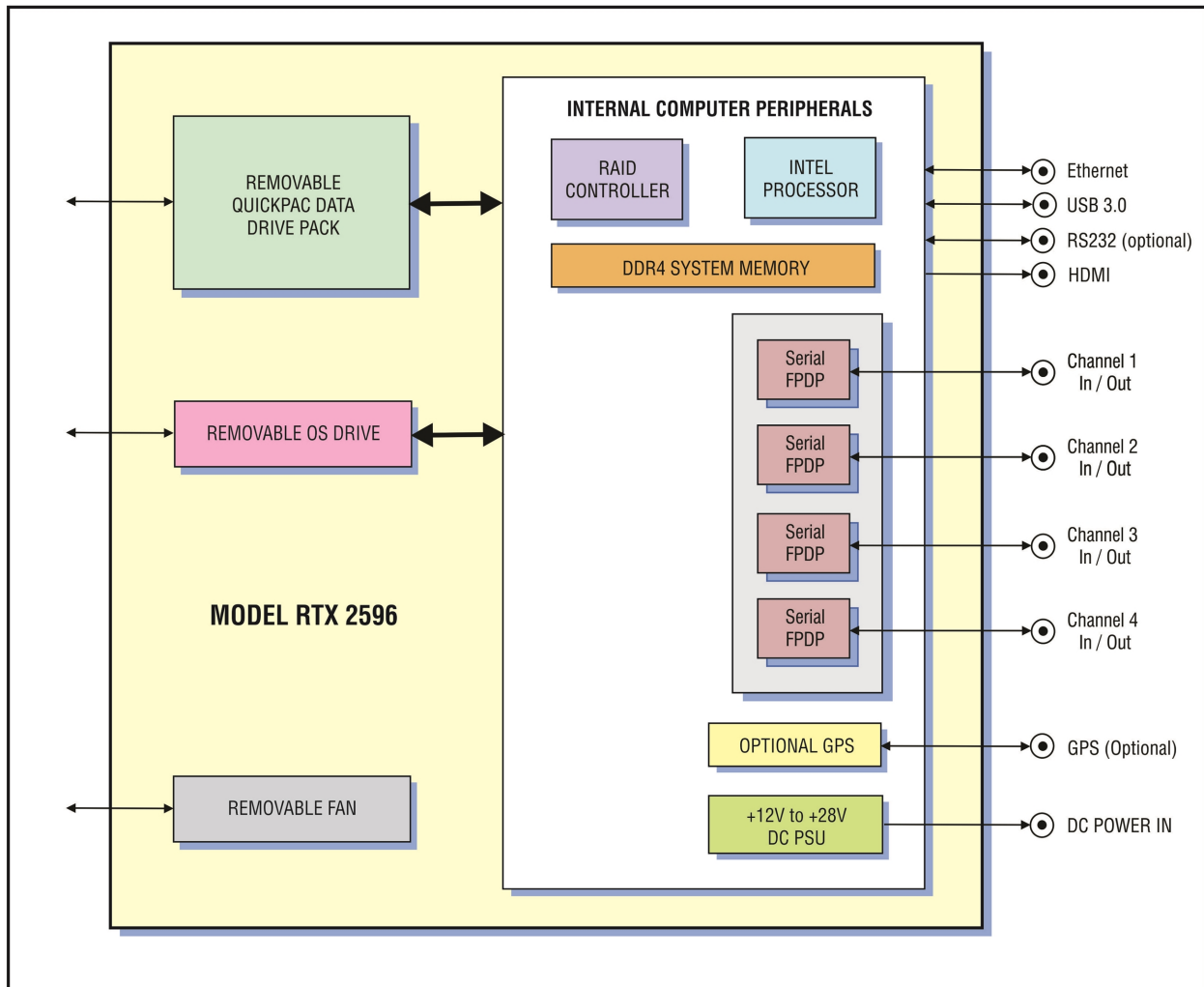

Extremely Rugged Design

Designed to operate in the toughest environments, the recorder chassis keeps all electronics sealed from the outside environment and removes heat by conducting to forced-air cooling channels. Designed to operate from -40° to $+60^{\circ}$ C, these recorders can operate in most thermal environments, making them ideal for UAVs, aircraft pods, tight equipment bays, military vehicles and most outdoor environments.

The sealed $\frac{1}{2}$ ATR chassis uses MIL-STD circular connectors for I/O to control RF emissions while protecting the recorder's electronics from humidity, water, dust, sand and salt fog. In addition to meeting MIL-STD 461 specifications for radiated RF emissions, conducted emission military specifications are met by design with a built-in conducted emissions filter.

Designed to handle high levels of shock and vibration, this extremely rugged chassis supports Pentek's extensive line of I/O front-ends, providing multichannel, wide bandwidth RF recording and a variety of digital interface recording options. An optional GPS receiver provides precise time stamping of recordings and can track and record the GPS position of the system during operation.

QuickPac Drive Packs

The Pentek QuickPac drive packs add a valuable convenience to the RTX SFF 1/2 ATR recorder by providing the ability to quickly remove all data storage from the recorder via the front panel. With up to 61 TB of solid-state data storage capacity, QuickPac drive packs can be easily removed from the recorder by loosening a set of captive thumb screws. A separate operating system drive can be removed as well, allowing users to extract all non-volatile memory from the system in just a few seconds.

QuickPac drive packs include a high insertion cycle connector to provide an extremely durable data storage drive for Talon recorders. Spare QuickPac drive packs can replace full ones in seconds to minimize mission downtime. QuickPac drive packs filled with mission data can be taken to the lab where data can be retrieved, post-processed and archived with a Talon offload system.

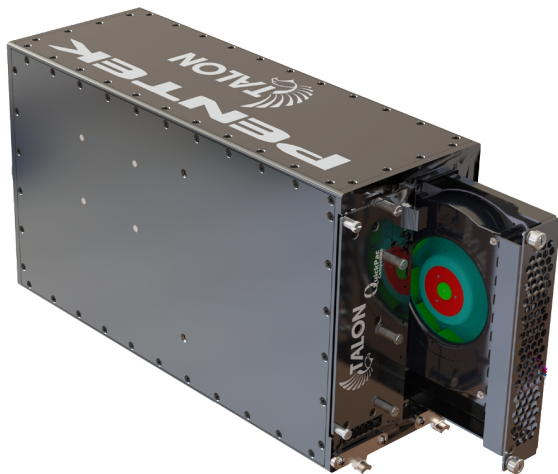

Sealed Chassis with Cooling Design

The Talon RTX SFF chassis seals the internal electronics from the outside environment by providing an inner plenum that is designed to extract heat from the internal electronics via conduction. The plenum is supplemented by a removable fan that is used to pull air from the front of the chassis and exhaust it through the rear. Only the fan is exposed to the outside environment, assuring the electronics are protected in the sealed chassis. The removable fan pulls air from the front of the chassis across heat sinks that are welded to the inner plenum of the chassis.

The welded heat sinks are attached directly to all heat-generating electronics within the sealed chassis, providing a conduction-cooled path to the inner plenum. This assures optimal cooling while maintaining a sealed design. The inner plenum can be replaced to provide other cooling options, such as liquid or conduction cooling.

SystemFlow Overview

All Talon recorders include the Pentek SystemFlow[®] recording software. SystemFlow software provides three ways for users to configure and control a Talon recorder:

- The **SystemFlow GUI** provides an easy out-of-the-box experience which allows the operator to open the box and begin recording with a point and click user interface.
- The **SystemFlow API** provides a set of C-callable libraries that allow engineers to develop their own user interface to configure and control their Talon recorder.
- The **SystemFlow Telnet** interface provides a simple set of commands to configure and control the recorder. This eliminates the need for any software development and is most suitable for unmanned operation.

SystemFlow software allows the recorder to be set up to run autonomously by implementing scripts using the API or telnet interface. All three interfaces can be run from a remote connection over Gigabit Ethernet and all allow for easy access to recorded files.



SystemFlow GUI

The SystemFlow GUI shows a block diagram of the system and provides the user with a control interface for the recording system. It includes Configure, Record, Playback, and Status screens, each with intuitive controls and indicators. The user can easily move between screens to configure parameters, control and monitor a recording, and play back a recorded stream.

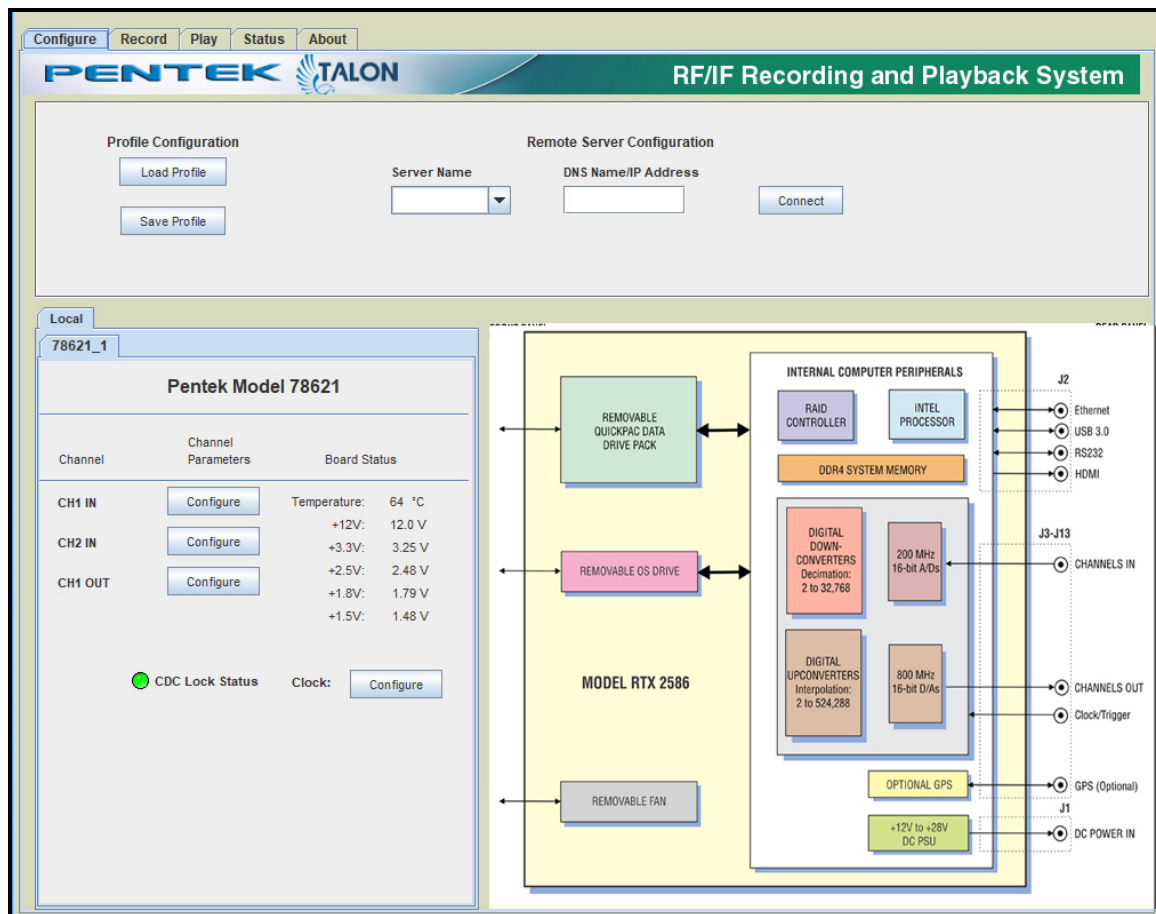

SystemFlow API

SystemFlow includes a complete API (Application Programming Interface) supporting control and status queries of all operations of the Talon recorder from a custom application.

High-level C-language function calls and the supporting device drivers allow users to incorporate the RTX 2596 as a high-performance server front end to a larger system. This is supported using a socket interface through the Ethernet port, either to a local host or through an internet link for remote, standalone acquisition. Recorded NTFS files can be easily retrieved through the same connection.

Below is an example of controlling recording via the SystemFlow API.

```

728     }
729     //transfer until end of disk
730     else if (transferType == TRANSFER_END_OF_DISK)
731     {
732         recordParams->transferTime    = 0;           // must set to 0
733         recordParams->transferLength  = 0;           // must set to 0
734     }
735
736     //////////////////////////////////////////////////////////////////// Start the record ////////////////////////////////////////////////////////////////////
737     SetConsoleTextAttribute (hConsole, FOREGROUND_GREEN | FOREGROUND_INTENSITY );
738     printf("\nCase 6: RTS_Record\n");
739     SetConsoleTextAttribute (hConsole, wOldColorAttrs);
740
741     //trigger immediately
742     if(recordParams->trigger == RTS_TRIGGER_IMMEDIATELY)
743     {
744         //send record command
745         if ((error = RTS_Record(++msgNum,
746                               serverInfo,
747                               recordParams,
748                               recordChanId,
749                               fileName[0])) != RTS_SUCCESS)
750         {
751             printf("Record Error # 0x%lx.\n", error);
752             exitHandler(error);
753             goto freeMem;
754         }
755
756         Sleep(500);
757     }
758
759     //wait for SW trigger
760     else if(recordParams->trigger == RTS_WAIT_FOR_SW_TRIGGER)
761     {
762         //send record command which set up record and start DMA
763         if ((error = RTS_Record(++msgNum,
764                               serverInfo,
765                               recordParams,
766                               recordChanId,
767                               fileName[0])) != RTS_SUCCESS)

```

SystemFlow Telnet

The Talon telnet facility is an optional feature that can be requested when ordering one of Pentek's Talon recording systems. The Talon telnet facility allows you to control a Talon recorder from a remote computer. You also can use the Talon recorder's SystemFlow [Signal Viewer](#) to remotely monitor real-time data.

Pentek's [Telnet Facility for Talon Recording Systems User's Guide](#) provides instructions for setting up telnet access and describes all the supported commands.

Below is an example of use of the "record" command:

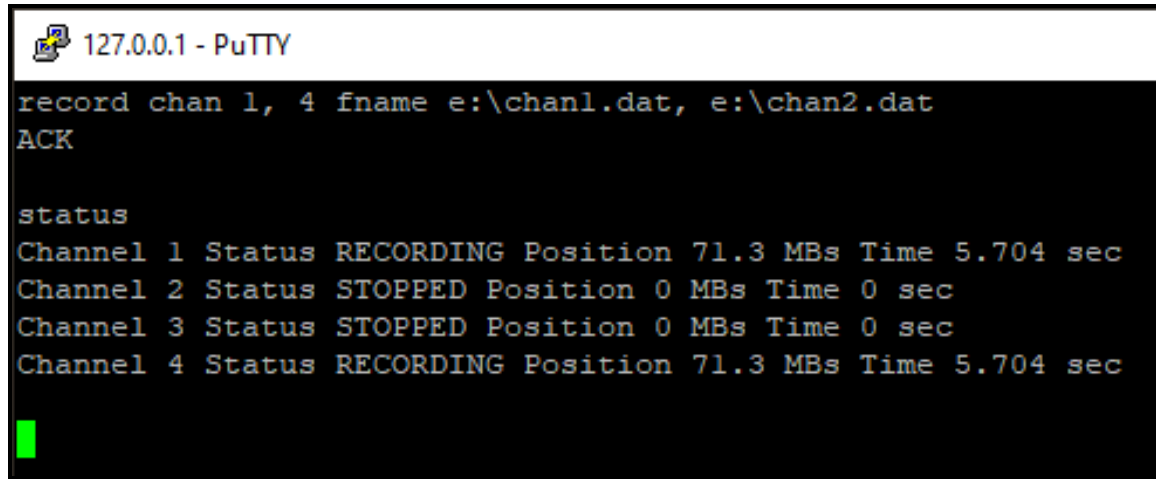

```
127.0.0.1 - PuTTY
record chan 1, 4 fname e:\chan1.dat, e:\chan2.dat
ACK

status
Channel 1 Status RECORDING Position 71.3 MBs Time 5.704 sec
Channel 2 Status STOPPED Position 0 MBs Time 0 sec
Channel 3 Status STOPPED Position 0 MBs Time 0 sec
Channel 4 Status RECORDING Position 71.3 MBs Time 5.704 sec
```

Signal Viewer

The SystemFlow Signal Viewer includes a virtual oscilloscope and spectrum analyzer for signal monitoring in both the time and frequency domains. It is extremely useful for previewing live inputs prior to recording, and for monitoring signals as they are being recorded to help ensure successful recording sessions. The viewer can also be used to inspect and analyze the recorded files after the recording is complete.

Advanced signal analysis capabilities include automatic calculators for signal amplitude and frequency, second and third harmonic components, THD (total harmonic distortion), and SINAD (signal to noise and distortion). With time and frequency zoom, panning modes, and dual, annotated cursors to mark and measure points of interest, the SystemFlow Signal Viewer can often eliminate the need for a separate oscilloscope or spectrum analyzer in the field.

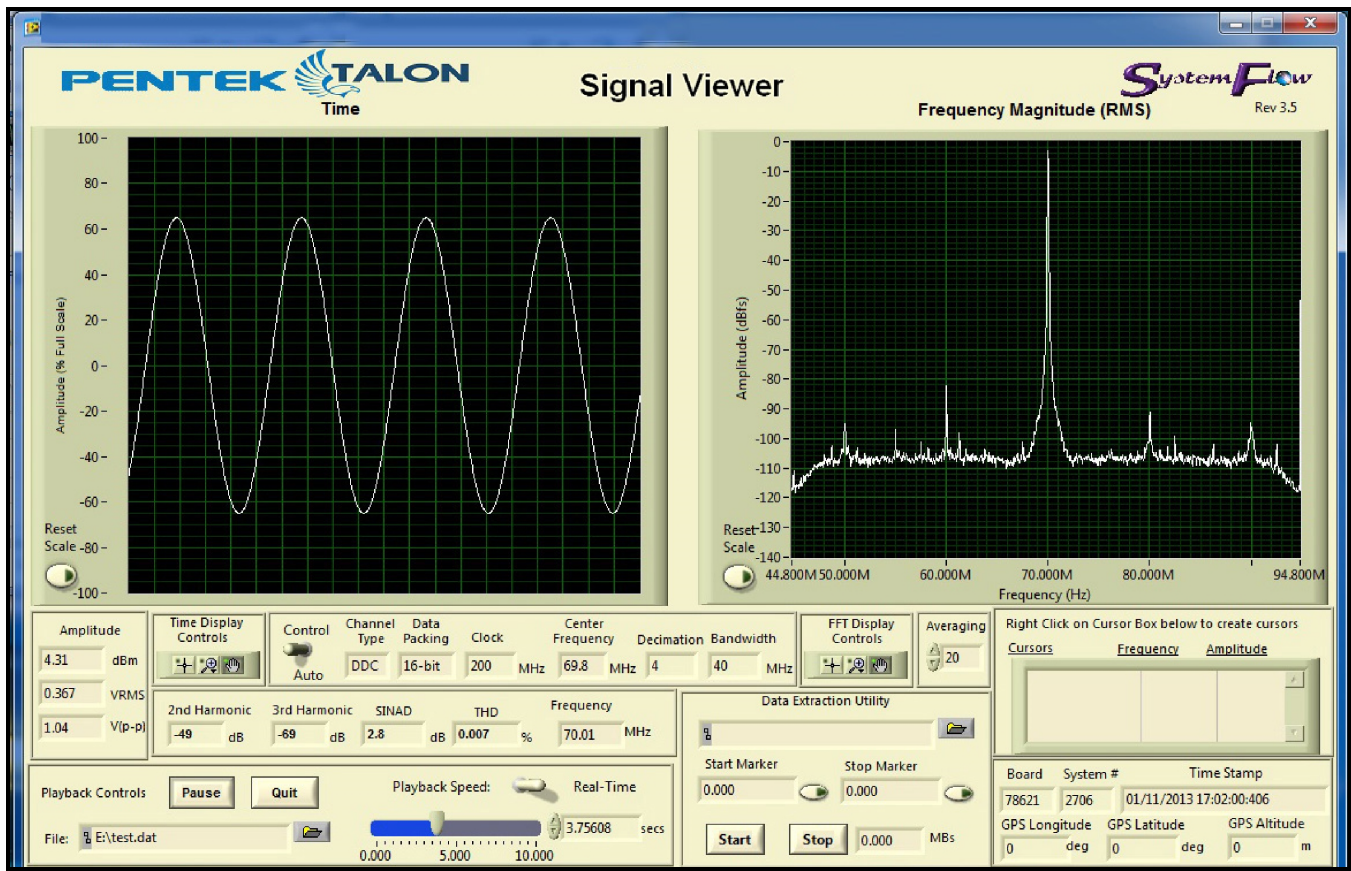

Specifications

Physical Characteristics

Dimension: 7.688" H x 4.880" W x 14.125" D (231 mm H x 124 mm W x 359 mm D)

Weight: 18 lb (8 kg)

Storage: One removable QuickPac® with up to 61 TB total storage

RAID Levels: 0, 5, and 6 available

One removable Operating System SSD (M.2 form factor - 250 GB standard)

Front Panel I/O

One removable Operating System SSD

One removable QuickPac (Thumbscrew removable)

One removable System Fan (Thumbscrew removable)

Rear Panel I/O

Chassis power connector: Glenair 805-005-07M12-2PA

Mating cable power connector: Glenair 805-002-16M12-2SA

Computer I/O

Chassis Computer I/O Connector: Glenair 805-003-07M19-85SA

Signals, 1 each: HDMI, USB 3.0, Ethernet (RJ 45), RS232 (optional)

Mating cable computer I/O Connector: Glenair 802-002-16M19-85PA

SFPDP I/O

Chassis Connector: Glenair 183-001ME08-11-1PN

Type: One SuperNine MT ferrule

Signals: 4 SFPDP channels on 8 fibers

Mating Cable Connector: Glenair 183-001MEG6-11-1SN

Cooling

Conduction-cooled to inner air channel

Removable fan inserted in air channel to pull air across sealed heat sinks

Optional direct conduction cooling and other methods available

Power

+12 to +28 VDC (+24 VDC nominal) 110 Watts power consumption typical, 160 W maximum

Processor and Memory

Processor: Intel Core i7, 7700K, 7th Generation, Quad Core, 4.2 GHz

DRAM: 8 GB DDR 4, optional 16 to 32 GB

Environmental

Operating Temp: -40° to +60° C (-20° C start-up)

Storage Temp: -65° to +85° C

Altitude: 60,000 feet

Relative Humidity: 5 to 95%, condensing

Vibration: MIL-STD-810 Method 514.5

Shock: MIL-STD-810 Method 516.5

EMI/EMC: MIL-STD-461 - CE101, CE102, CS101, RE101, RE102, RS101

Sand and Dust: MIL-STD-810 Method 510

Ordering Information

Click [here](#) for more information.

Model	Description
Talon RTX 2596	Serial FPDP Extreme 1/2 ATR Recorder

Storage Options	
Option -410	3.84 TB SSD storage capacity
Option -415	7.68 TB SSD storage capacity
Option -420	15.36 TB SSD storage capacity
Option -430	30.72 TB SSD storage capacity
Option -460	61 TB SSD storage capacity
RAID Configurations	
Standard	RAID Level 0
Option -285	RAID Level 5
Option -286	RAID Level 6
Additional Options	
Option -261	GPS time and position stamping
Standard	8 GB DDR System Memory
Option -309	16 GB DDR System Memory
Option -310	32 GB System Memory
Storage and general options may change. Contact your Pentek representative for the latest information and valid option combinations.	

Accessory Products

Power Cable	
Part Number:	2186-102
Length:	3 feet
MIL-STD Connector:	Glenair 805-002-16M12-2SA
Leads:	Two 14-gauge wires, unterminated

Power Connector	
Part Number:	2186-103
MIL-STD Connector:	Glenair 805-002-16M12-2SA

Power Connector Backshell	
Part Number:	2186-104
Backshell:	Glenair 370MS038M1006-6

Computer I/O Breakout Cable	
Part Number:	2186-202
Length:	3 feet
MIL-STD Connector:	Glenair 802-002-16M19-85PA
Breakout connectors (1 each):	HDMI female, USB 3.0 female, RJ45 female, RS232 female (optional), power button, reset button

Computer I/O Connector	
Part Number:	2186-203
MIL-STD Connector:	Glenair 802-002-16M19-85PA

Computer I/O Connector Backshell	
Part Number:	2186-204
Backshell:	Glenair 370MS038M1410-8

1/2 ATR Tray	
Part Number:	8380-258
Dimensions	15" L x 5.01" W x 1.223" H
Material:	.063 6061-T6 aluminum
Finish:	Chem Film per MIL-DTL-5541F, Type 1, Class 3

Spare QuickPac Drive Pack	
Part Number:	8336
Capacities:	Option 615: 7.6 TB
	Option 620: 15.3 TB
	Option 625: 30.7 TB

Lifetime Support

Pentek offers the worldwide military embedded computing community shorter development time, reliable, rugged solutions for a variety of environments, reduced costs, mature software development tools, and **free** lifetime support that our customers can depend on: phone and email access to engineering staff as well as software updates. Take advantage of Pentek's expertise in delivering high-performance radar, communications, SIGINT, and data acquisition MIL-Aero solutions worldwide for over 30 years.

Pricing and Availability

To learn more about our products or to discuss your specific application please contact [your local representative](#) or Pentek directly:

Pentek, Inc.
 One Park Way
 Upper Saddle River, NJ 07458 USA
 Tel: +1 (201) 818-5900
 Email: sales@pentek.com