

XCalibur4646

Intel® Xeon® D-1500 Family Processor-Based 6U VPX Module with Dual 10GbE, Dual XMC Sites, and Onboard Security FPGA

- ▶ Supports Intel® Xeon® D-1500 family processors (formerly Broadwell-DE)
- ▶ Designed with SecureCOTS™ technology to support enhanced security and trusted computing
- ▶ Microsemi SmartFusion®2 SoC with 1 GB DDR3-667 ECC SDRAM and 32 MB SPI Flash
- ▶ 6U OpenVPX™ (VITA 46) module
- ▶ VITA 46.11 Tier 1 and Tier 2 IPMI Controller (IPMC)
- ▶ Compatible with multiple OpenVPX™ (VITA 65) profiles
- ▶ Ruggedized Enhanced Design Implementation (REDI) per VITA 48
- ▶ Supports two XMC modules
- ▶ Conduction or air cooling
- ▶ Up to 16 Xeon®-class cores in a single, power-efficient SoC package
- ▶ 4, 8, or 12 core SKUs available with native extended temperature support
- ▶ Up to 32 GB of DDR4-2133 ECC SDRAM in two channels
- ▶ Up to 64 GB of onboard SLC SATA NAND flash
- ▶ Two 10 Gigabit Ethernet ports and up to three Gigabit Ethernet ports
- ▶ Two x4 or one x8 PCI Express Gen3 interface to backplane
- ▶ Four SATA ports
- ▶ One USB 3.0 port and one USB 2.0 port to the back panel and one USB 3.0 port to the optional front panel
- ▶ Four RS-232/422/485 serial ports
- ▶ coreboot firmware powered by Intel® FSP
- ▶ Wind River VxWorks BSP
- ▶ X-ES Enterprise Linux (XEL) BSP
- ▶ Contact factory for availability of Green Hills INTEGRITY, QNX Neutrino, and LynxWorks LynxOS BSPs



XCalibur4646

The XCalibur4646 is a secure, high-performance, 6U OpenVPX™, single board computer based on the Intel® Xeon® D-1500 family processors. The Intel® Xeon® D processor can provide up to 16 Xeon®-class cores for high-bandwidth processing and I/O applications. The integrated SecureCOTS™ technology can protect critical data from being modified or observed and provides an ideal solution where stringent security capabilities are required.

The XCalibur4646 includes a customizable Microsemi SmartFusion®2 security SoC with 1 GB of ECC DDR3 to implement the SecureCOTS™ features. It can host many types of custom functions, such as data encryption, and additionally supports the ability to control, intercept, and monitor the Xeon® D subsystem, implement penalties, and interface to the system through I/O directly connected to the VPX backplane. Circuit board enhancements and optional, optimized Two-Level Maintenance (2LM) metalwork provides added protection to the physical hardware.

The XCalibur4646 optimizes network performance and power efficiency with two 10GBASE-KR Ethernet interfaces direct from the CPU and two 1000BASE-T Ethernet interfaces to the VPX backplane. It accommodates up to 32 GB of DDR4-2133 ECC SDRAM in two channels and up to 64 GB of SLC SATA NAND flash in addition to other I/O ports, including USB, SATA, and four configurable RS-232/422/485 serial ports through the backplane connectors. The XCalibur4646 supports additional expansion from two XMC sites, each of which includes a x8 PCIe connection to the Intel® Xeon® D processor and mezzanine I/O mapped directly to the VPX backplane.

The XCalibur4646 is a powerful, feature-rich solution for the next generation of compute-intensive embedded applications. Wind River VxWorks and X-ES Enterprise Linux (XEL) BSPs are available. The XCalibur4646 uses coreboot, to provide fast boot times and significantly simplify code traceability over legacy BIOS implementations.

X-ES

Extreme Engineering Solutions

...Always Fast

Extreme Engineering Solutions

3225 Deming Way, Suite 120 • Middleton, WI 53562

Phone: 608.833.1155 • Fax: 608.827.6171

sales@xes-inc.com • <https://www.xes-inc.com>

Processor

- Intel® Xeon® D-1500 family processors (formerly Broadwell-DE)
- Up to 16 Xeon®-class cores in a single, power-efficient SoC package
- 4, 8, or 12 core SKUs available with native extended temperature support

Memory

- Up to 32 GB of DDR4-2133 ECC SDRAM in two channels
- Up to 64 GB of SLC NAND flash
- 32 MB NOR boot flash
- 64 kB EEPROM

OpenVPX™

- VITA 46.11 (System Management on VPX)
- Compatible with multiple OpenVPX™ (VITA 65) profiles
- One x8 PCI Express Gen3-capable port to P2
- Two 10 Gigabit Ethernet ports to P4
- Two 10/100/1000BASE-T Ethernet ports to P4
- XMC I/O to P3, P4, P5, P6, mapping X38s+X12d+X8d or P64s+X12d+X8d

Front Panel I/O (Optional)

- One 10/100/1000BASE-T Ethernet port
- One USB 3.0 port
- One RS-232 serial port
- One RS-232/422/485 serial port
- General-purpose LEDs

Back Panel I/O

- Configurable x8 PCI Express Gen3 interfaces to P2
- Two 10GBASE-KR Ethernet ports to P4
- Two 10/100/1000BASE-T Ethernet ports
- Four SATA ports capable of 6 Gb/s
- One USB 3.0 port and one USB 2.0 port
- Four RS-232/422/485 serial ports
- Eight SmartFusion@2 GPIO

Security and Management

- Microsemi SmartFusion@2 security FPGA with 1 GB DDR3-667 ECC SDRAM and 32 MB SPI flash
- Designed with SecureCOTS™ technology to support enhanced security and trusted computing
- SmartFusion@2 with embedded memory, random number generator, crypto-cores, PUF, and supports complete zeroization
- System voltage monitor, power-on/reset control, non-volatile write-protection control
- Environmental sensors (see product manual)
- Trusted Platform Module (TPM) 1.2 or 2.0 (optional)

XMC

- x8 PCI Express Gen3-capable port to XMC site 0
- x8 PCI Express Gen3-capable port to XMC site 1
- Six SmartFusion@2 GPIO per site

Additional Features

- Optional VITA 46.11 Tier 1 and Tier 2 IPMI Controller (IPMC)
- IEEE 1588 support

Software Support

- Wind River VxWorks BSP
- X-ES Enterprise Linux (XEL) BSP
- coreboot firmware powered by Intel® FSP
- Contact factory for availability of Green Hills INTEGRITY, QNX Neutrino, and LynuxWorks LynxOS BSPs

Physical Characteristics

- 6U VPX-REDI conduction- or air-cooled form factor
- Dimensions: 233 mm x 160 mm
- 0.8 in. pitch
- 1.0 in. pitch is compliant to the VITA 48.2 Type 1, Two-Level Maintenance (2LM) standard (optional)

Environmental Requirements

Contact factory for appropriate board configuration based on environmental requirements.

- Supported ruggedization levels (see chart below): 1, 3, 5
- Conformal coating available as an ordering option
- Thermal performance will vary based on CPU frequency and application

Power Requirements

- Power will vary based on configuration and usage. Please consult factory.

Ruggedization Level	Level 1	Level 3	Level 5
Cooling Method	Standard Air-Cooled	Rugged Air-Cooled	Conduction-Cooled
Operating Temperature	0 to +55°C ambient (300 LFM)	-40 to +70°C (600 LFM)	-40 to +85°C (board rail surface)
Storage Temperature	-40 to +85°C ambient	-55 to +105°C ambient	-55 to +105°C (maximum)
Vibration	0.002 g ² /Hz (maximum), 5 to 2000 Hz	0.04 g ² /Hz (maximum), 5 to 2000 Hz	0.1 g ² /Hz (maximum), 5 to 2000 Hz
Shock	20 g, 11 ms sawtooth	30 g, 11 ms sawtooth	40 g, 11 ms sawtooth
Humidity	0% to 95% non-condensing	0% to 95% non-condensing	0% to 95% non-condensing

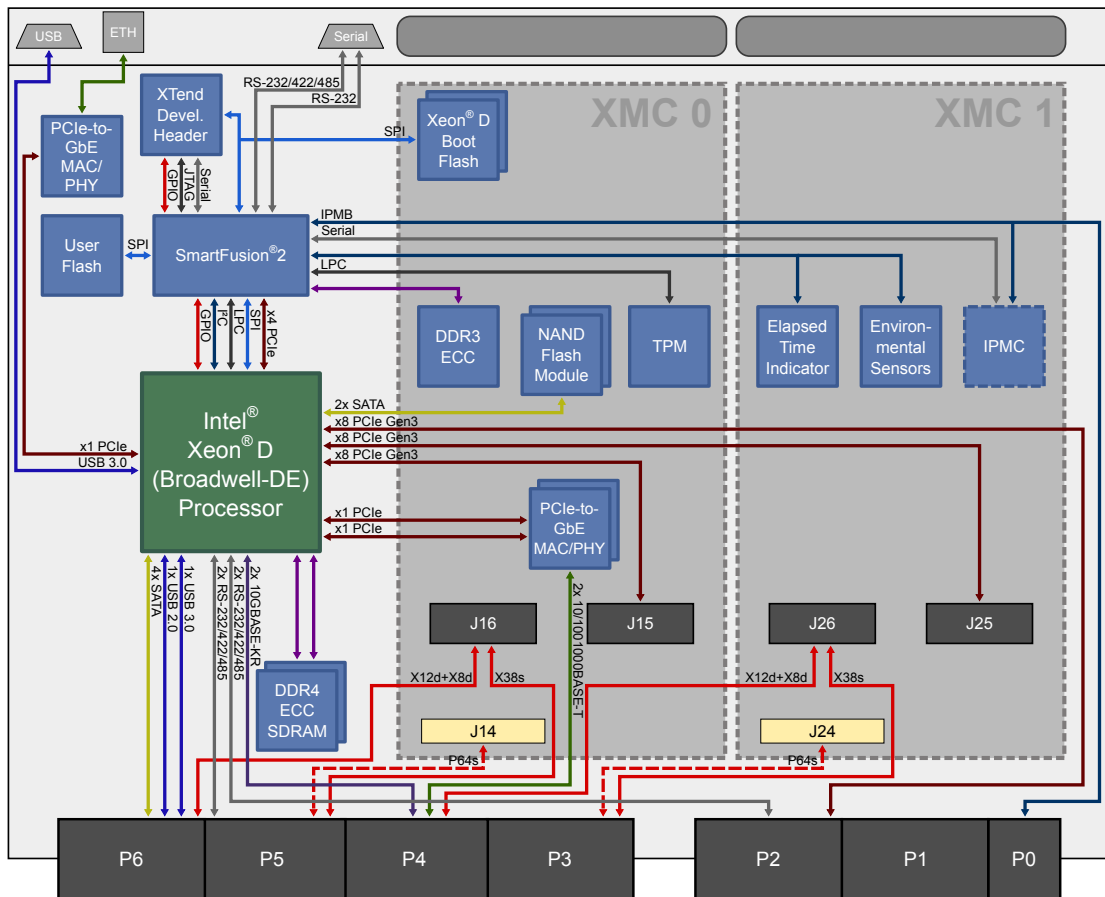

XCalibur4646

