

## DN2.59x - 16 channel 16 bit digitizerNETBOX up to 125 MS/s

- 4, 8 or 16 channels with 20 MS/s up to 125 MS/s
- Software selectable single-ended or differential inputs
- Simultaneously sampling on all channels
- Separate ADC and amplifier per channel
- complete on-board calibration
- 6 input ranges:  $\pm 200$  mV up to  $\pm 10$  V
- 512 MSample/1 GSample acquisition memory
- Programmable input offset of  $\pm 100\%$
- Window, pulse width, re-arm, spike, OR/AND trigger
- Streaming, ABA mode, Multiple Recording, Gated Sampling, Timestamps

Speed	SNR	ENOB
20 MS/s	up to 81.0 dB	up to 13.2 LSB
40 MS/s	up to 75.3 dB	up to 12.2 LSB
125 MS/s	up to 73.3 dB	up to 11.8 LSB



- Ethernet Remote Instrument
- LXI Core 2011 compatible
- GBit Ethernet Interface
- Sustained streaming mode up to 70 MB/s
- Direct Connection to PC/Laptop
- Connect anywhere in company LAN
- Embedded Webserver for Maintenance/Updates
- Embedded Server option for open Linux platform

Operating Systems	SBench 6 Professional Included	Drivers
<ul style="list-style-type: none"> <li>• Windows 7 (SP1), 8, 10</li> <li>• Linux Kernel 2.6, 3.x, 4.x</li> <li>• Windows/Linux 32 and 64 bit</li> </ul>	<ul style="list-style-type: none"> <li>• Acquisition, Generation and Display of analog and digital data</li> <li>• Calculation, Documentation and Import, Export</li> </ul>	<ul style="list-style-type: none"> <li>• LabVIEW, MATLAB, LabWindows/CVI</li> <li>• Visual C++, C++ Builder, GNU C++, VB.NET, C#, J#, Delphi, Java, Python, IVI</li> </ul>

Model	Single-Ended Inputs		Differential Inputs	
DN2.592-04	4 channels	20 MS/s	4 channels	20 MS/s
DN2.592-08	8 channels	20 MS/s	4 channels	20 MS/s
DN2.592-16	16 channels	20 MS/s	8 channels	20 MS/s
DN2.593-04	4 channels	40 MS/s	4 channels	40 MS/s
DN2.593-08	8 channels	40 MS/s	4 channels	40 MS/s
DN2.593-16	16 channels	40 MS/s	8 channels	40 MS/s
DN2.596-04	4 channels	125 MS/s	4 channels	125 MS/s
DN2.596-08	8 channels	80 MS/s	4 channels	125 MS/s
DN2.596-16	16 channels	80 MS/s	8 channels	125 MS/s
	8 channels	125 MS/s		

### General Information

The digitizerNETBOX DN2.49x series allows recording of up to 16 channels with sampling rates of 80 MS/s or 8 channels with sampling rates of 125 MS/s. These Ethernet Remote instruments offer outstanding A/D features both in resolution and signal quality. The inputs can be switched between Single-Ended with a programmable offset and True Differential. If used in differential mode each two inputs are connected together reducing the number of available channels by half. Importantly, the high-resolution 16-bit ADCs deliver sixteen times more resolution than digitizers using older 12-bit technology and 256 times more resolution than what is available from digital scopes that commonly use 8-bit ADCs. The digitizerNETBOX can be installed anywhere in the company LAN and can be remotely controlled from a host PC.

## Software Support

### Windows Support

The digitizerNETBOX/generatorNETBOX can be accessed from Windows 7, Windows 8, Windows 10 (each 32 bit and 64 bit). Programming examples for Visual C++, C++ Builder, LabWindows/CVI, Delphi, Visual Basic, VB.NET, C#, J#, Python, Java and IVI are included.

### Linux Support



The digitizerNETBOX/generatorNETBOX can be accessed from any Linux system. The Linux support includes SMP systems, 32 bit and 64 bit systems, versatile programming examples for Gnu C++, Python as well as drivers for MATLAB for Linux. SBench 6, the powerful data acquisition and analysis software from Spectrum is also included as a Linux version.

### Discovery Protocol

Physical Location	
Bus No	0
Device No	0
Function No	0
Slot No	0
IP	192.168.169.14
VISA	TCPIP[0]:192.168.169.14::inst0::INSTR

The Discovery function helps you to find and identify any Spectrum LXI instruments, like the digitizerNETBOX and generatorNETBOX, available to your computer on the network. The Discovery function will also locate any Spectrum card products that are managed by an installed Spectrum Remote Server somewhere on the network.

After running the discovery function the card information is cached and can be directly accessed by SBench 6. Furthermore the qualified VISA address is returned and can be used by any software to access the remote instrument.

### SBench 6 Professional

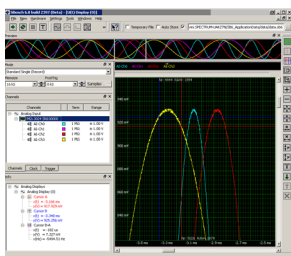

The digitizerNETBOX and generatorNETBOX can be used with Spectrum's powerful software SBench 6 – a Professional license for the software is already installed in the box. SBench 6 supports all of the standard features of the instrument. It has a variety of display windows as well as analysis, export and documentation

functions.

- Available for Windows XP, Vista, Windows 7, Windows 8, Windows 10 and Linux
- Easy to use interface with drag and drop, docking windows and context menus
- Display of analog and digital data, X-Y display, frequency domain and spread signals
- Designed to handle several GBytes of data
- Fast data preview functions

### IVI Driver

The IVI standards define an open driver architecture, a set of instrument classes, and shared software components. Together these provide critical elements needed for instrument interchangeability. IVI's defined Application Programming Interfaces (APIs) standardize common measurement functions reducing the time needed to learn a new IVI instrument.

The Spectrum products to be accessed with the IVI driver can be locally installed data acquisition cards, remotely installed data acquisition cards or remote LXI instruments like digitizerNETBOX/generatorNETBOX. To maximize the compatibility with existing IVI based software installations, the Spectrum IVI

driver supports IVI Scope, IVI Digitizer and IVI FGen class with IVI-C and IVI-COM interfaces.

### Third-party Software Products

Most popular third-party software products, such as LabVIEW, MATLAB or LabWindows/CVI are supported. All drivers come with examples and detailed documentation.

### Embedded Webserver



Instrument Welcome Page	
Instrument Model	DN2.465-08
Manufacturer	Spectrum GmbH
Serial Number	1234
Description	Spectrum GmbH, DN2.465-08, 1234, 3.32.13608
LXI Features	LXI Core 2011
LXI Version	LXI Device Specification 2011 rev. 1.4
Host Name	192.168.169.20
mDNS Host Name	DN2_465-08_sn1234.local
MAC Address	0C:C4:7A:B3:C2:A2
TCP/IP Address	192.168.169.20
Firmware Revision	40
Software Revision	3.32.13608
Instrument Address String [VISA]	TCPIP::192.168.169.20::INSTR
LAN ID Indicator	<input type="checkbox"/> Enable

The integrated webserver follows the LXI standard and gathers information on the product, set up of the Ethernet configuration and current status. It also allows the setting of a configuration password, access to documentation and updating of the complete instrument firmware, including the embedded remote server and the webserver.

### Hardware features and options

#### LXI Instrument



The digitizerNETBOX and generatorNETBOX are fully LXI instrument compatible to LXI Core 2011 following the LXI Device Specification

2011 rev. 1.4. The digitizerNETBOX/generatorNETBOX has been tested and approved by the LXI Consortium.

Located on the front panel is the main on/off switch, LEDs showing the LXI and Acquisition status and the LAN reset switch.

#### digitizerNETBOX/generatorNETBOX chassis version V2



The chassis version V2 got a complete re-design to allow some new features that improve the handling especially for mobile and shared usage:

- 8 bumper edges protect the chassis, the desk and other components on it. The bumper edges allow to store the chassis either vertically or horizontally and the lock-in structure allows to stack multiple chassis with a secure fit onto each other. For 19" rack mount montage the bumpers can be unmounted and replaced by the 19" rack mount option
- The handle allows to easily carry the chassis around in juts one hand.
- A standard GND screw on the back of the chassis allows to connect the metal chassis to measurement ground to reduce noise based on ground loops and ground level differences.

#### Front Panel



Standard BNC connectors are used for all analog input or output signals and all trigger and clock signals. No special adapter cables are needed and the connection is secure even when used in a moving environment.

Custom front panels are available on request even for small series, be it SMA, LEMO connectors or custom specific connectors.

### Ethernet Connectivity



The GBit Ethernet connection can be used with COTS Ethernet cabling as well as special industrial grade Buccaneer Ethernet cables. The integration into a standard LAN allows to connect the digitizerNETBOX/generatorNETBOX either directly to a desktop PC or Laptop or it is possible to place the instrument somewhere in the company LAN and access it from any desktop over the LAN.

### DC Power Supply Option



The digitizerNETBOX/generatorNETBOX can be equipped with an internal DC power supply which replaces the standard AC power supply. Two different power supply options are available that range from 9V to 36V. Contact the sales team if other DC levels are required.

Using the DC power supply the digitizerNETBOX/generatorNETBOX can be used for mobile applications together with a Laptop in automotive or airborne applications.

### Input Amplifier

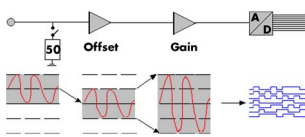

The analog inputs can be adapted to real world signals using a wide variety of settings that are individual for each channel. By using software commands the input termination can be changed

between 50 Ohm and 1 MOhm, one can select a matching input range and the signal offset can be compensated for.

### Differential inputs

With a simple software command the inputs can individually be switched from single-ended (in relation to ground) to differential by combining each two single-ended inputs to one differential input. When the inputs are used in differential mode the A/D converter measures the difference between two lines with relation to system ground.

### Automatic on-board calibration

All of the channels are calibrated in factory before the board is shipped. To compensate for different variations like PC power supply, temperature and aging, the software driver provides routines for an automatic onboard offset and gain calibration of all input ranges. All the cards contain a high precision on-board calibration reference.

### Ring buffer mode

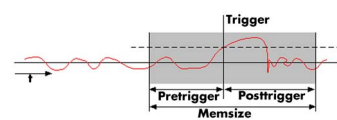

The ring buffer mode is the standard mode of all oscilloscope instruments. Digitized data is continuously written into a ring memory until a

trigger event is detected. After the trigger, post-trigger samples are recorded and pre-trigger samples can also be stored. The number of pre-trigger samples available simply equals the total ring memory size minus the number of post trigger samples.

### FIFO mode

The FIFO mode is designed for continuous data transfer between remote instrument and PC memory or hard disk. The control of the

data stream is done automatically by the driver on interrupt request. The complete installed on-board memory is used for buffer data, making the continuous streaming extremely reliable.

### Channel trigger

The data acquisition instruments offer a wide variety of trigger modes. Besides the standard signal checking for level and edge as known from oscilloscopes it's also possible to define a window trigger. All trigger modes can be combined with the pulsewidth trigger. This makes it possible to trigger on signal errors like too long or too short pulses. In addition to this a re-arming mode (for accurate trigger recognition on noisy signals) the AND/OR conjunction of different trigger events is possible. As a unique feature it is possible to use deactivated channels as trigger sources.

### External trigger I/O

All instruments can be triggered using an external TTL signal. It's possible to use positive or negative edge also in combination with a programmable pulse width. An internally recognised trigger event can - when activated by software - be routed to the trigger connector to start external instruments.

### Pulse width

Defines the minimum or maximum width that a trigger pulse must have to generate a trigger event. Pulse width can be combined with channel trigger, pattern trigger and external trigger.

### Multiple Recording

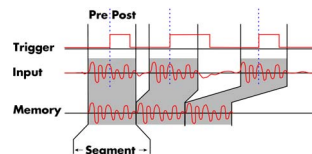

The Multiple Recording mode allows the recording of several trigger events with an extremely short re-arming time. The hardware doesn't need to be restarted in between. The on-board memory is divided in several segments of the same size. Each of them is filled with data if a trigger event occurs. Pre- and posttrigger of the segments can be programmed. The number of acquired segments is only limited by the used memory and is unlimited when using FIFO mode.

### Gated Sampling

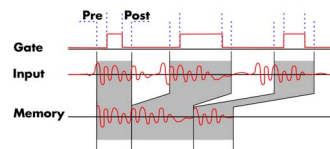

The Gated Sampling mode allows data recording controlled by an external gate signal. Data is only recorded if the gate signal has a programmed level. In addition a pre-area before start

of the gate signal as well as a post area after end of the gate signal can be acquired. The number of gate segments is only limited by the used memory and is unlimited when using FIFO mode.

### Timestamp

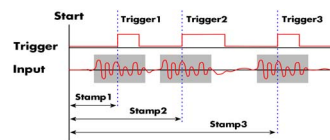

The timestamp function writes the time positions of the trigger events in an extra memory. The timestamps are relative to the start of recording, a defined zero time, externally synchronized to a radio clock, an IRIG-B or a GPS receiver. Using the external synchronization gives a precise time relation for acquisitions of systems on different locations.

## **ABA mode**

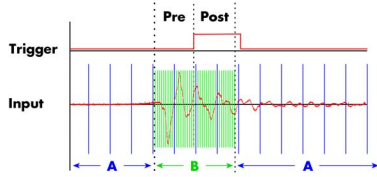

The ABA mode combines slow continuous data recording with fast acquisition on trigger events. The ABA mode works like a slow data logger combined with a fast digitizer. The exact

position of the trigger events is stored as timestamps in an extra memory.

## **Option Embedded Server**

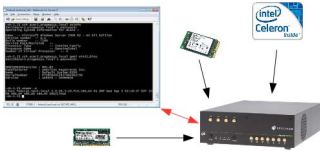

The option turns the digitizer-NETBOX/generatorNETBOX in a powerful PC that allows to run own programs on a small and remote data acquisition system. The digitizerNET-

BOX/generatorNETBOX is en-

hanced by more memory, a powerful CPU, a freely accessible internal SSD and a remote software development access method.

The digitizerNETBOX/generatorNETBOX can either run connected to LAN or it can run totally independent, storing data to the internal SSD. The original digitizerNETBOX/generatorNETBOX remote instrument functionality is still 100% available. Running the embedded server option it is possible to pre-calculate results based on the acquired data, store acquisitions locally and to transfer just the required data or results parts in a client-server based software structure. A different example for the digitizerNETBOX/generatorNETBOX embedded server is surveillance/logger application which can run totally independent for days and send notification emails only over LAN or offloads stored data as soon as it's connected again.

Access to the embedded server is done through a standard text based Linux shell based on the ssh secure shell.

## **External clock I/O**

Using a dedicated connector a sampling clock can be fed in from an external system. It's also possible to output the internally used sampling clock to synchronise external equipment to this clock.

## **Reference clock**

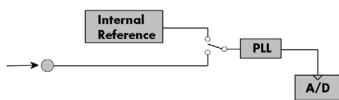

The option to use a precise external reference clock (normally 10 MHz) is necessary to synchronize the instrument for high-quality

measurements with external equipment (like a signal source). It's also possible to enhance the quality of the sampling clock in this way. The driver automatically generates the requested sampling clock from the fed in reference clock.

## DN2 / DN6 Technical Data

### Analog Inputs

Resolution		16 bit (can be reduced to acquire simultaneous digital inputs)
Input Range	software programmable	±200 mV, ±500 mV, ±1 V, ±2 V, ±5 V, ±10 V
Input Type	software programmable	Single-ended or True Differential
Input Offset (single-ended)	software programmable	programmable to ±100% of input range in steps of 1%
ADC Differential non linearity (DNL)	ADC only	592x: ±0.2/±0.8 LSB (typ./max.) 593x: ±0.5/±0.9 LSB (typ./max.) 594x: ±0.5/±0.9 LSB (typ./max.) 596x: ±0.5/±0.9 LSB (typ./max.)
ADC Integral non linearity (INL)	ADC only	592x: ±1.0/±2.3 LSB (typ./max.) 593x: ±2.0/±7.5 LSB (typ./max.) 594x: ±2.0/±7.5 LSB (typ./max.) 596x: ±2.0/±7.5 LSB (typ./max.)
Offset error (full speed)	after warm-up and calibration	≤ 0.1%
Gain error (full speed)	after warm-up and calibration	≤ 0.1%
Crosstalk: Signal 1 MHz, 50 Ω	range ≤ ±1V range ≥ ±2V	≤ 95 dB on adjacent channels ≤ 90 dB on adjacent channels
Crosstalk: Signal 10 MHz, 50 Ω	range ≤ ±1V range ≥ ±2V	≤ 87 dB on adjacent channels ≤ 85 dB on adjacent channels
Analog Input impedance	software programmable	50 Ω / 1 MΩ    30 pF
Analog input coupling	fixed	DC
Over voltage protection	range ≤ ±1V	±5 V (1 MΩ), 3.5 Vrms (50 Ω)
Over voltage protection	range ≥ ±2V	±50 V (1 MΩ), 5 Vrms (50 Ω)
CMRR (Common Mode Rejection Ratio)	range ≤ ±1V	100 kHz: 75 dB, 1 MHz: 60 dB, 10 MHz: 40 dB
CMRR (Common Mode Rejection Ratio)	range ≥ ±2V	100 kHz: 55 dB, 1 MHz: 52 dB, 10 MHz: 50 dB
Channel selection (single-ended inputs)	software programmable	1, 2, 4 or 8 channels (maximum is model dependent)
Channel selection (true differential inputs)	software programmable	1, 2 or 4 channels (maximum is model dependent)

### Trigger

Available trigger modes	software programmable	Channel Trigger, External, Software, Window, Pulse, Re-Arm, Spike, Or/And, Delay
Trigger level resolution	software programmable	14 bit
Trigger edge	software programmable	Rising edge, falling edge or both edges
Trigger pulse width	software programmable	0 to [4G - 1] samples in steps of 1 sample
Trigger delay	software programmable	0 to [4G - 1] samples in steps of 1 samples
Trigger holdoff (for Multi, ABA, Gate)	software programmable	0 to [4G - 1] samples in steps of 1 samples
Multi, ABA, Gate: re-arming time		< 24 samples (+ programmed pretrigger + programmed holdoff )
Pretrigger at Multi, ABA, Gate, FIFO	software programmable	8 up to [32 kSamples / number of active channels] in steps of 8
Posttrigger	software programmable	8 up to [8G - 4] samples in steps of 8 (defining pretrigger in standard scope mode)
Memory depth	software programmable	8 up to [installed memory / number of active channels] samples in steps of 8
Multiple Recording/ABA segment size	software programmable	8 up to [installed memory / number of active channels] samples in steps of 8
Internal/External trigger accuracy		1 sample
External trigger		<b>Ext</b>
External trigger type		Single level comparator
External trigger impedance	software programmable	50 Ω / 5 kΩ
External trigger input level		±5 V (5 kΩ), ±2.5 V (50 Ω),
External trigger over voltage protection		±20 V (5 kΩ), 5 Vrms (50 Ω)
External trigger sensitivity (minimum required signal swing)		200 mVpp
External trigger level	software programmable	±5 V in steps of 1 mV
External trigger bandwidth	50 Ω 5 kΩ	DC to 400 MHz DC to 300 MHz
Minimum external trigger pulse width		≥ 2 samples
		<b>X1, X2, X3</b>
		3.3V LVTTTL logic inputs
		For electrical specifications refer to „Multi Purpose I/O lines“ section.
		n.a.
		DC to 125 MHz
		≥ 2 samples

## Clock

Clock Modes	software programmable	internal PLL, external clock, external reference clock, sync
Internal clock range (PLL mode)	software programmable	internal reference: 1 kS/s to max (see „Dynamic Parameters“ table below) external reference: TBD to max (see „Dynamic Parameters“ table below)
Internal clock accuracy		≤ ±1.0 ppm (at time of calibration in production)
Internal clock aging		≤ ±0.5 ppm / year
Internal clock setup granularity		TDB
External reference clock range	software programmable	1 MHz to 125 MHz (preliminary)
Direct external clock to internal clock delay		4.3 ns
Direct external clock range		see „Dynamic Parameters“ table below
External clock type		Single level comparator
External clock input level		±5 V (5 kΩ), ±2.5 V (50 Ω),
External clock input impedance	software programmable	50 Ω / 5 kΩ
External clock over voltage protection		±20 V (5 kΩ), 5 Vrms (50 Ω)
External clock sensitivity (minimum required signal swing)		200 mVpp
External clock level	software programmable	±5 V in steps of 1 mV
External clock edge		rising edge used
External reference clock input duty cycle		45% - 55%
Clock output electrical specification		Available via Multi Purpose output X0. Refer to „Multi Purpose I/O lines“ section.
Synchronization clock divider	software programmable	TBD
ABA mode clock divider for slow clock	software programmable	8 up to (64k - 8) in steps of 8

## Connectors

Analogue Inputs		9 mm BNC female (one for each single-ended input)	Cable-Type: Cab-9m-xx-xx
Trigger Input		9 mm BNC female	Cable-Type: Cab-9m-xx-xx
Clock/Reference Clock Input		9 mm BNC female	Cable-Type: Cab-9m-xx-xx
Clock Output, Multi-Purpose X0		9 mm BNC female	Cable-Type: Cab-9m-xx-xx
Multi-Purpose I/O X1, X2, X3	Programmable Direction	9 mm BNC female	Cable-Type: Cab-9m-xx-xx

## Option digitizerNETBOX/generatorNETBOX embedded server (DN2.xxx-Emb, DN6.xxx-Emb)

CPU	Intel Quad Core 2 GHz
System memory	4 GByte RAM
System data storage	Internal 128 GByte SSD
Development access	Remote Linux command shell (ssh), no graphical interface (GUI) available
Accessible Hardware	Full access to Spectrum instruments, LAN, front panel LEDs, RAM, SSD
Integrated operating system	OpenSuse 12.2 with kernel 3.4.6.

## Ethernet specific details

LAN Connection	Standard RJ45 or Ethernet Buccaneer(R) for screw connection
LAN Speed	Auto Sensing: GBit Ethernet, 100BASE-T, 10BASE-T
Sustained Streaming speed	DN2.20, DN2.46, DN2.47, DN2.49, DN2.60 up to 70 MByte/s DN6.46, DN6.49 DN2.59, DN2.22, DN2.44, DN2.66 up to 100 MByte/s DN6.59, DN6.22, DN6.44, DN6.66
Used LAN Ports	Webserver: 80 mDNS Daemon: 5353 VISA Discovery Protocol: 111, 9757 UPNP Daemon: 1900 Spectrum Remote Server: 1026, 5025

## Power connection details

Mains AC power supply	Input voltage: 100 to 240 VAC, 50 to 60 Hz
AC power supply connector	IEC 60320-1-C14 (PC standard coupler)
Power supply cord	power cord included for Schuko contact (CEE 7/7)

## Certification, Compliance, Warranty

EMC Immunity	Compliant with CE Mark
EMC Emission	Compliant with CE Mark
Product warranty	5 years starting with the day of delivery
Software and firmware updates	Life-time, free of charge

## Clock Limitations and Bandwidth

	M2p.592x, DN2.592-xx DN6.592-xx	M2p.593x DN2.593-xx DN6.593-xx	M2p.594x	M2p.596x DN2.596-xx DN6.596-xx
max internal/external clock	20 MS/s	40 MS/s	80 MS/s	125 MS/s
min internal clock	1 kS/s	1 kS/s	1 kS/s	1 kS/s
min clock for synchronization with star-hub				
min direct external clock	1 MS/s	1 MS/s	1 MS/s	1 MS/s
-3 dB bandwidth	> 10 MHz	> 20 MHz	> 40 MHz	> 60 MHz

## RMS Noise Level (Zero Noise), typical figures

		<b>M2p.592x, DN2.592-xx, DN6.592-xx</b>					
Input Range		$\pm 200$ mV	$\pm 500$ mV	$\pm 1$	$\pm 2$ V	$\pm 5$ V	$\pm 10$ V
Voltage resolution		6.1 $\mu$ V	15.3 $\mu$ V	30.5 $\mu$ V	61.0 $\mu$ V	152.6 $\mu$ V	305.2 $\mu$ V
50 $\Omega$		<4.0 LSB <25 $\mu$ V	<2.6 LSB <40 $\mu$ V	<2.1 LSB <65 $\mu$ V	<4.3 LSB <263 $\mu$ V	<2.6 LSB <397 $\mu$ V	<2.1 LSB <641 $\mu$ V
1 M $\Omega$							

		<b>M2p.593x, DN2.593-xx, DN6.593-xx</b>					
Input Range		$\pm 200$ mV	$\pm 500$ mV	$\pm 1$	$\pm 2$ V	$\pm 5$ V	$\pm 10$ V
Voltage resolution		6.1 $\mu$ V	15.3 $\mu$ V	30.5 $\mu$ V	61.0 $\mu$ V	152.6 $\mu$ V	305.2 $\mu$ V
50 $\Omega$		<6.0 LSB <37 $\mu$ V	<5.0 LSB <77 $\mu$ V	<4.5 LSB <138 $\mu$ V	<6.5 LSB <397 $\mu$ V	<5.0 LSB <763 $\mu$ V	<4.5 LSB <1.4 mV
1 M $\Omega$							

		<b>M2p.594x</b>					
Input Range		$\pm 200$ mV	$\pm 500$ mV	$\pm 1$	$\pm 2$ V	$\pm 5$ V	$\pm 10$ V
Voltage resolution		6.1 $\mu$ V	15.3 $\mu$ V	30.5 $\mu$ V	61.0 $\mu$ V	152.6 $\mu$ V	305.2 $\mu$ V
50 $\Omega$		<7.0 LSB <43 $\mu$ V	<5.5 LSB <85 $\mu$ V	<4.5 LSB <138 $\mu$ V	<7.5 LSB <458 $\mu$ V	<5.5 LSB <840 $\mu$ V	<4.5 LSB <1.4 mV
1 M $\Omega$		<7.5 LSB <46 $\mu$ V	<5.8 LSB <9 $\mu$ V	<4.5 LSB <138 $\mu$ V	<7.7 LSB <470 $\mu$ V	<5.8 LSB <886 $\mu$ V	<4.5 LSB <1.4 mV

		<b>M2p.596x, DN2.596-xx, DN6.596-xx</b>					
Input Range		$\pm 200$ mV	$\pm 500$ mV	$\pm 1$	$\pm 2$ V	$\pm 5$ V	$\pm 10$ V
Voltage resolution		6.1 $\mu$ V	15.3 $\mu$ V	30.5 $\mu$ V	61.0 $\mu$ V	152.6 $\mu$ V	305.2 $\mu$ V
50 $\Omega$		<9.0 LSB <55 $\mu$ V	<6.8 LSB <104 $\mu$ V	<5.5 LSB <168 $\mu$ V	<9.0 LSB <550 $\mu$ V	<6.8 LSB <1.1 mV	<5.5 LSB <1.7 mV
1 M $\Omega$							

## Dynamic Parameters, typical figures

		<b>M2p.592x, DN2.592-xx, DN6.592-xx</b>					
Test - sampling rate		20 MS/s					
Input Range		$\pm 200$ mV	$\pm 500$ mV	$\pm 1$	$\pm 2$ V		
Test Signal Frequency		1 MHz	1 MHz	1 MHz	1 MHz	1 MHz	1 MHz
SNR (typ)					$\geq 81.0$ dB		
THD (typ)					$\leq -86.5$ dB		
SFDR (typ), excl. harm.					$\geq 103$ dB		
ENOB (based on SNR)					$\geq 13.2$ LSB		
ENOB (based on SINAD)					$\geq 13.0$ LSB		

		<b>M2p.593x, DN2.593-xx, DN6.593-xx</b>					
Test - sampling rate		40 MS/s					
Input Range		$\pm 200$ mV	$\pm 500$ mV	$\pm 1$	$\pm 2$ V		
Test Signal Frequency		1 MHz	10 MHz	1 MHz	10 MHz	1 MHz	10 MHz
SNR (typ)					$\geq 75.3$ dB	$\geq 75.3$ dB	
THD (typ)					$\leq -86.1$ dB	$\leq -67.2$ dB	
SFDR (typ), excl. harm.					$\geq 101$ dB	$\geq 97.0$ dB	
ENOB (based on SNR)					$\geq 12.2$ LSB	$\geq 12.2$ LSB	
ENOB (based on SINAD)					$\geq 12.2$ LSB	$\geq 10.8$ LSB	

		<b>M2p.594x</b>					
Test - sampling rate		80 MS/s					
Input Range		$\pm 200$ mV	$\pm 500$ mV	$\pm 1$	$\pm 2$ V		
Test Signal Frequency		1 MHz	10 MHz	1 MHz	10 MHz	1 MHz	10 MHz
SNR (typ)		$\geq 70.6$ dB	$\geq 70.5$ dB	$\geq 72.9$ dB	$\geq 72.8$ dB	$\geq 74.2$ dB	$\geq 74.2$ dB
THD (typ)		$\leq -87.3$ dB	$\leq -76.9$ dB	$\leq -86.6$ dB	$\leq -76.3$ dB	$\leq -84.8$ dB	$\leq -70.1$ dB
SFDR (typ), excl. harm.		$\geq 97.5$ dB	$\geq 105$ dB	$\geq 101$ dB	$\geq 104$ dB	$\geq 100$ dB	$\geq 100$ dB
ENOB (based on SNR)		$\geq 11.4$ LSB	$\geq 11.4$ LSB	$\geq 11.8$ LSB	$\geq 11.8$ LSB	$\geq 12.0$ LSB	$\geq 12.0$ LSB
ENOB (based on SINAD)		$\geq 11.4$ LSB	$\geq 11.3$ LSB	$\geq 11.8$ LSB	$\geq 11.5$ LSB	$\geq 12.0$ LSB	$\geq 11.1$ LSB

<b>M2p.594x, DN2.596-xx, DN6.596-xx</b>									
Test - sampling rate	125 MS/s								
Input Range	±200 mV		±500 mV		±1		±2 V		
Test Signal Frequency	1 MHz	10 MHz	1 MHz	10 MHz	1 MHz	10 MHz	1 MHz	10 MHz	
SNR (typ)					≥ 73.3 dB	≥ 73.2 dB			
THD (typ)					≤ -83.3 dB	≤ -69.9 dB			
SFDR (typ), excl. harm.					≥ 98.5 dB	≥ 98.1 dB			
ENOB (based on SNR)					≥ 11.8 LSB	≥ 11.8 LSB			
ENOB (based on SINAD)					≥ 11.7 LSB	≥ 11.0 LSB			

Dynamic parameters are measured at ±1 V input range (if no other range is stated) and 50Ω termination with the samplerate specified in the table. Measured parameters are averaged 20 times to get typical values. Test signal is a pure sine wave generated by a signal generator and a matching bandpass filter. Amplitude is >99% of FSR. SNR and RMS noise parameters may differ depending on the quality of the used PC. SNR = Signal to Noise Ratio, THD = Total Harmonic Distortion, SFDR = Spurious Free Dynamic Range, SINAD = Signal Noise and Distortion, ENOB = Effective Number of Bits.

## DN2 specific Technical Data

### Environmental and Physical Details DN2.xxx

Dimension of Chassis without connectors or bumpers	L x W x H	366 mm x 267 mm x 87 mm
Dimension of Chassis with 19" rack mount option	L x W x H	366 mm x 482.6 mm x 87 mm (2U height)
Weight (1 internal acquisition/generation module)		6.3 kg, with rack mount kit: 6.8 kg
Weight (2 internal acquisition/generation modules)		6.7 kg, with rack mount kit 7.2 kg
Warm up time		10 minutes
Operating temperature		0°C to 50°C
Storage temperature		-10°C to 70°C
Humidity		10% to 90%

### Power Consumption

	230 VAC		12 VDC		24 VDC	
4 channel versions, standard memory	0.24 A	55 W	TBD	TBD	TBD	TBD
8 channel versions, standard memory	0.26 A	60 W	TBD	TBD	TBD	TBD
16 channel versions, standard memory	0.37 A	85 W	TBD	TBD	TBD	TBD
4 channel versions, 1 x 2 GSample memory	0.28 A	65 W	TBD	TBD	TBD	TBD
8 channel versions, 1 x 2 GSample memory	0.30 A	70 W	TBD	TBD	TBD	TBD
16 channel versions, 2 x 2 GSample memory	0.48 A	105 W	TBD	TBD	TBD	TBD

### MTBF

MTBF	100000 hours
------	--------------



## Block diagram of digitizerNETBOX DN2

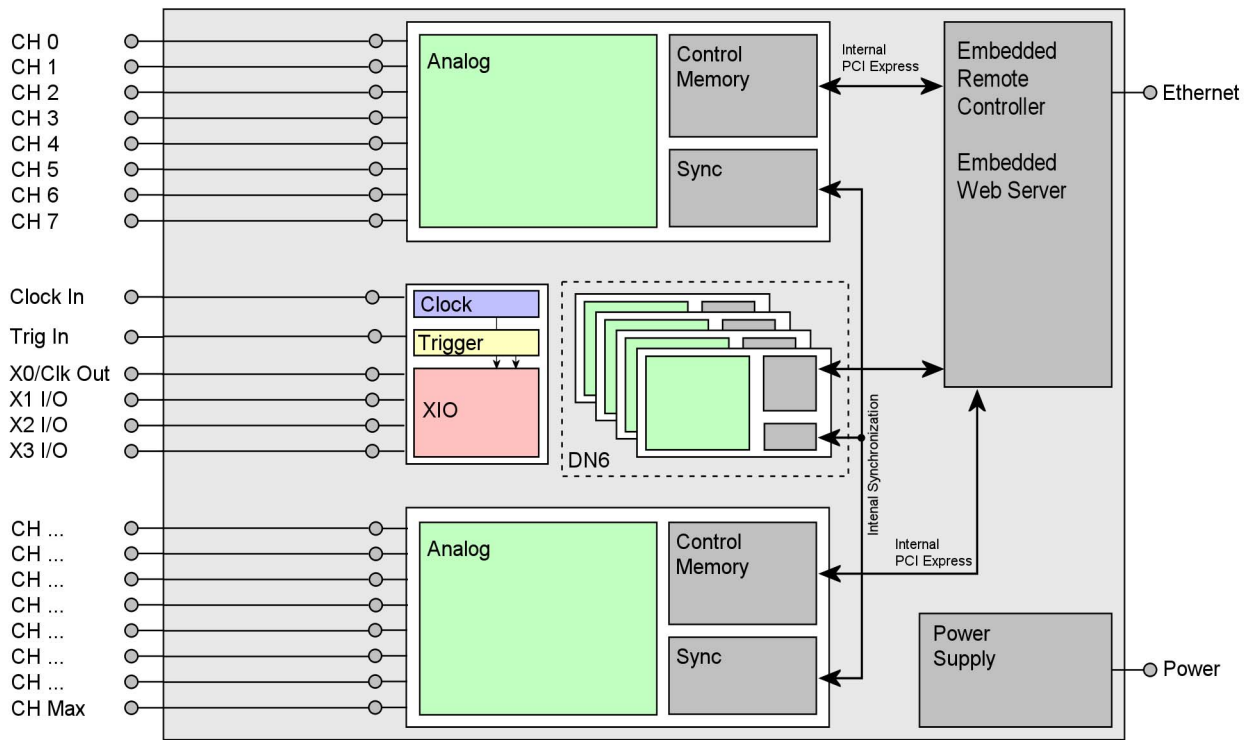

- The number of maximum channels and internal digitizer modules and existence of a synchronization Star-Hub is model dependent.

## Block diagram of digitizerNETBOX module DN2.59x

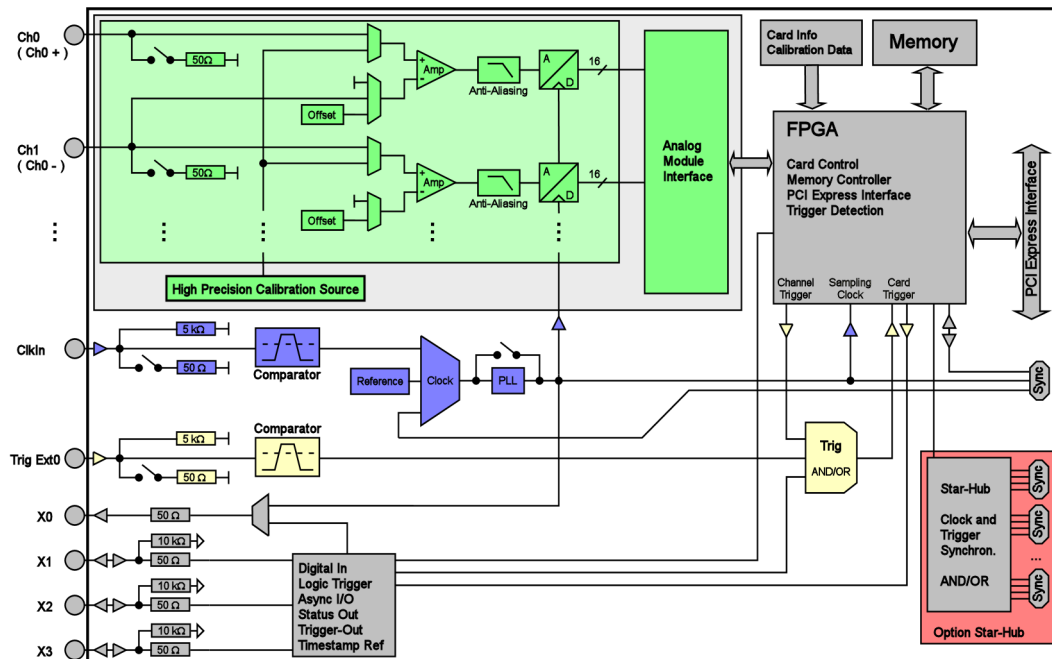

## Order Information

The digitizerNETBOX is equipped with a large internal memory for data storage and supports standard acquisition (Scope), FIFO acquisition (streaming), Multiple Recording, Gated Sampling, ABA mode and Timestamps. Operating system drivers for Windows/Linux 32 bit and 64 bit, drivers and examples for C/C++, IVI (Scope and Digitizer class), LabVIEW (Windows), MATLAB (Windows and Linux), LabWindows/CVI, .NET, Delphi, Visual Basic, Java, Python and a Professional license of the oscilloscope software SBench 6 are included.

The system is delivered with a connection cable meeting your countries power connection. Additional power connections with other standards are available as option.

### digitizerNETBOX DN2 - Ethernet/LXI Interface

Order no.	A/D Resolution	Bandwidth	Memory	Single-Ended Inputs		Differential Inputs	
DN2.592-04	16 Bit	10 MHz	1 x 512 MSamples	4 channels	20 MS/s	4 channels	20 MS/s
DN2.592-08	16 Bit	10 MHz	1 x 512 MSamples	8 channels	20 MS/s	4 channels	20 MS/s
DN2.592-16	16 Bit	10 MHz	2 x 512 MSamples	16 channels	20 MS/s	8 channels	20 MS/s
DN2.593-04	16 Bit	20 MHz	1 x 512 MSamples	4 channels	40 MS/s	4 channels	40 MS/s
DN2.593-08	16 Bit	20 MHz	1 x 512 MSamples	8 channels	40 MS/s	4 channels	40 MS/s
DN2.593-16	16 Bit	20 MHz	2 x 512 MSamples	16channels	40 MS/s	8 channels	40 MS/s
DN2.596-04	16 Bit	60 MHz	1 x 512 MSamples	4 channels	125 MS/s	4 channels	125 MS/s
DN2.596-08	16 Bit	60 MHz	1 x 512 MSamples	4 channels	125 MS/s	4 channels	125 MS/s
				8 channels	80 MS/s		
DN2.596-16	16 Bit	60 MHz	2 x 512 MSamples	8 channels	125 MS/s	8 channels	125 MS/s
				16 channels	80 MS/s		

## Options

Order no.	Option
DN2.xxx-Rack	19" rack mounting set for self mounting
DN2.xxx-Emb	Extension to Embedded Server: CPU, more memory, SSD. Access via remote Linux secure shell (ssh)
DN2.xxx-DC24	24 VDC internal power supply. Replaces AC power supply. Accepts 18 V to 36 V DC input. Screw terminals
DN2.xxx-BTPWR	Boot on Power On: the digitizerNETBOX/generatorNETBOX automatically boots if power is switched on.

## Calibration

Order no.	Option
DN2.xxx-Recal	Recalibration of complete digitizerNETBOX/generatorNETBOX DN2 including calibration protocol

## BNC Cables

for Connections	Connection	Length	to SMA male	to SMA female	to BNC male	to SMB female
All	BNC male	80 cm	Cab-9m-3mA-80	Cab-9m-3fA-80	Cab-9m-9m-80	Cab-9m-3f-80
All	BNC male	200 cm	Cab-9m-3mA-200	Cab-9m-3fA-200	Cab-9m-9m-200	Cab-9m-3f-200

### Technical changes and printing errors possible

SBench, digitizerNETBOX and generatorNETBOX are registered trademarks of Spectrum Instrumentation GmbH. Microsoft, Visual C++, Visual Basic, Windows, Windows 98, Windows NT, Window 2000, Windows XP, Windows Vista, Windows 7, Windows 8 and Windows 10 are trademarks/registered trademarks of Microsoft Corporation. LabVIEW, DASyLab, Diadem and LabWindows/CVI are trademarks/registered trademarks of National Instruments Corporation. MATLAB is a trademark/registered trademark of The Mathworks, Inc. Delphi and C++Builder are trademarks/registered trademarks of Embarcadero Technologies, Inc. Keysight VEE, VEE Pro and VEE OneLab are trademarks/registered trademarks of Keysight Technologies, Inc. FlexPro is a registered trademark of Weisang GmbH & Co. KG. PCIe, PCI Express and PCI-X and PCI-SIG are trademarks of PCI-SIG. LXI is a registered trademark of the LXI Consortium. PICMG and CompactPCI are trademarks of the PCI Industrial Computer Manufacturers Group. Oracle and Java are registered trademarks of Oracle and/or its affiliates. Intel and Intel Xeon are trademarks or registered trademarks of Intel Corporation. AMD and Opleron are trademarks or registered trademarks of Advanced Micro Devices. NVIDIA, CUDA, GeForce, Quadro and Tesla are trademarks/registered trademarks of NVIDIA Corporation.