

# FMC176, FMC VITA 57.1 Compliant

## Quad 250Mps A/D - Dual 5.6Gps D/A @ 14-bit

The FMC176 is a quad channel ADC and dual channel DAC FMC. This daughter card provides four 14-bit A/D channels at 250Mps and two 14-bit D/A channels at 5.6Gps (2.8Gps direct RF synthesis) clocked by either an internal clock source (optionally locked to an external reference) or an externally supplied sample clock. In addition, a trigger input for customized sampling control is available to users. The FMC176 daughter card is mechanically and electrically compliant to the FMC standard (ANSI/VITA 57.1).

The FMC176 has a high-pin count connector, front panel I/O, and can be used in a conduction cooled environment. The design is based on Analog devices' AD9250 dual channel 14-bit 250Mps Analog-to-Digital converter and Analog devices AD9129 single channel 14-bit 5.6Gps Digital-to-Analog converter. The analog signals are AC coupled connecting to MMCX or SSMC coax connectors on the front panel.

### FEATURES:

- Two AD9250: 4-channel 14-bit A/D up to 250 Mps - JESD204B
- Two AD9129: 2-channel 14-bit D/A up to 5.6 Gps (2.8Gps without 2:1 interpolation) - LVDS
- VITA 57.1-2010 compliant
- Conduction Cooled - Standard Option
- Single ended AC-coupled analog signals
- 10 MMCX/SSMC connectors available from the front panel
- Clock Source, Sampling Frequency, and Calibration through a SPI communication busses
- Flexible clock tree enables:
  - on board VCO: 2300MHz - 2650MHz
  - external reference clock
  - external sampling clock
- Power-down modes to switch off unused functions for system power savings
- Mil-I-46058c Conformal Coating Compliant (optional)
- HPC (high-pin count) compatible
- LVDS IO signaling

ANSI/VITA 47	Air-cooled		Conduction-cooled	
	EAC4	EAC6	ECC1	ECC4
Operating temperature	0C to +55C	-40C to +70C	0C to +55C	-40C to +85C
Storage temperature	-40C to +85C	-50C to +100C	-40C to +85C	-55C to +105C
Humidity	95%	95%	95%	95%
Operating vibration	5Hz to 100Hz PSD = 0.04g <sup>2</sup> /Hz 100 Hz to 1000 Hz PSD = 0.04 gs <sup>2</sup> /Hz 1000 Hz to 2000 Hz PSD decreasing at 6 dB/octave	5Hz to 100H PSD = 0.04g <sup>2</sup> /Hz 100 Hz to 1000 Hz PSD = 0.04 gs <sup>2</sup> /Hz 1000 Hz to 2000 Hz PSD decreasing at 6 dB/octave	5 Hz to 100 Hz PSD increasing at 3 dB/octave 100 Hz to 1000 Hz PSD = 0.1 g <sup>2</sup> /Hz 1000 Hz to 2000 Hz PSD decreasing at 6 dB/octave	5 Hz to 100 Hz PSD increasing at 3 dB/octave 100 Hz to 1000 Hz PSD = 0.1 g <sup>2</sup> /Hz 1000 Hz to 2000 Hz PSD decreasing at 6 dB/octave
Operating shock	20g, 11 millisecond, half-sine or 20g, 11 millisecond, terminal sawtooth shock pulses in all three axes	20g, 11 millisecond, half-sine or 20g, 11 millisecond, terminal sawtooth shock pulses in all three axes	40g, 11 millisecond shock half-sine or 40g, 11 millisecond, terminal sawtooth shock pulses in all three axes	40g, 11 millisecond shock half-sine or 40g, 11 millisecond, terminal sawtooth shock pulses in all three axes
Operating altitude	-1500 ft to 60,000 ft (with airflow)	-1500 ft to 60,000 ft (with airflow)	-1500 ft to 60,000 ft	-1500 ft to 60,000 ft
Conformal coating	Optional	Optional	Optional	Optional

# FMC176, FMC VITA 57.1 Compliant Quad 250Msps A/D - Dual 5.6Gsps D/A @ 14-bit

The FMC176 allows flexible control on clock source, analog input gain and over range detection through serial communication busses. Furthermore the card is equipped with power supply and temperature monitoring and offers several power-down modes to switch off unused functions in order to reduce system level power consumption. It is well suited for low power applications such as airborne where the highest level of performance is required while ensuring that mission range does not get affected.

## Specifications

### Application

- Direct RF Down Conversion
- Software defined radio (SDR)
- RADAR/SONAR
- Ultra Wideband Satellite Digital Receiver
- Medical equipment
- Aerospace and test instrumentation

### Support

- Stellar IP available for this product. A simple way to design FPGA firmware with automated code and bitstream generation
- Reference firmware design (VHDL)
- KC705 reference design soon available
- VC707 reference design soon available
- Fully supported on the 3U cPCI FC6301 and 3U VPX VP680
- Can be used on any VITA 57.1 compliant carrier card
- Reference ISE project for Virtex-7 and Kintex-7
- For support, please visit our support forum [www.abaco.com](http://www.abaco.com)

AS9100 Certified

## Block diagram

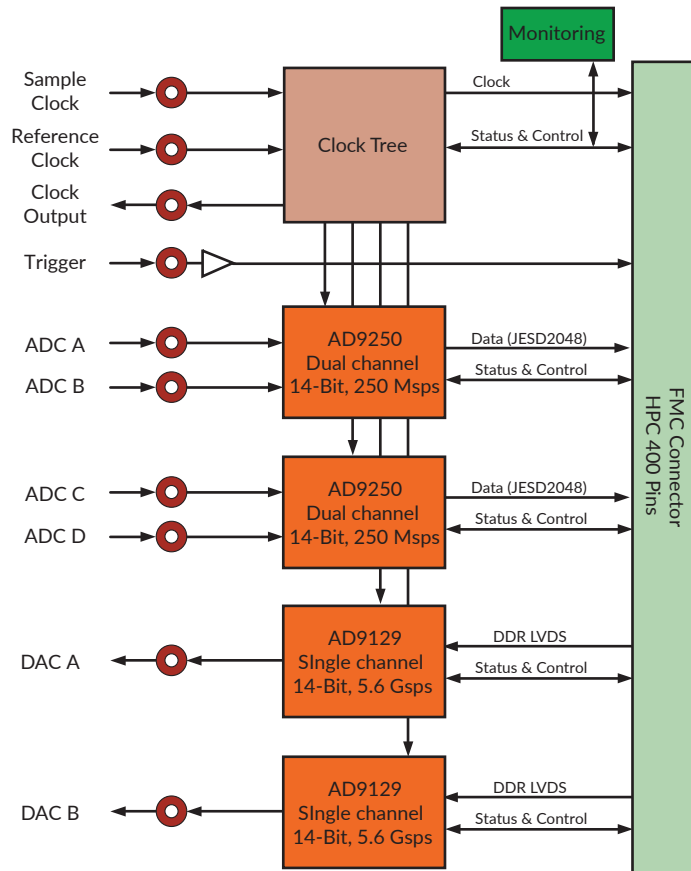

## Ordering information

Talk to us about your algorithmic requirements, Abaco Systems is a full-service firmware and software development house. We are a specialist at high performance FFT and Video Processing. Check with us, we may have IP Cores that meet requirements for your application, right off the shelf.



WE INNOVATE. WE DELIVER. YOU SUCCEED.

Americas: 866-OK-ABACO or +1-866-652-2226 Asia & Oceania: +81-3-5544-3973

Europe, Africa, & Middle East: +44 (0) 1327-359444

Locate an Abaco Systems Sales Representative visit: [abaco.com/products/sales](http://abaco.com/products/sales)

[abaco.com](http://abaco.com) @AbacoSys

©2016 Abaco Systems. All Rights Reserved. All other brands, names or trademarks are property of their respective owners. Specifications are subject to change without notice.

