

# SPR507B

## 4-Channel Serial FPDP Interface PMC/XMC Module with PCI Express x4 Gen 2 Interface

Designed for high-speed remote data transfer, the SPR507B offers a flexible interface with a wide range of connectivity options allowing support for almost any host. The choice of either PMC or XMC along with the option for any of five levels of ruggedization allows users to standardize on a single part number for all of their remote data transfer applications.

The low latency protocol used in sFPDP and the noise immunity of the fibre based data transport is the ideal combination for applications which require a dedicated data link to run between sources of data, such as high speed digitizer, to a remote data processing station. The SPR507B allows for fiber lengths up to 10km in length with the choice of single mode fibre.

The flexible architecture of the SPR507B allows for each fibre link to be configured independently (each link can operate in either direction).

The XMC form factor allows the SPR507B to be mounted on the latest generation high-

end SBC's for back end processing using the capabilities of multi-core CPUs, and provides the necessary data bandwidth to support the high speed capabilities of the module. The PCI-X interface implemented on the PMC version of the card will also support high speed throughput to Host memory. The scatter/gather mode of DMA implemented on the SPR507B allows for interrupt driven data transfer architectures, or for demand mode data transfer.

The SPR507B also includes 1 GBytes of high speed on-board storage in a FIFO (individual per channel) configuration. The FIFO is programmable in depth allowing an application to fine tune system latencies to achieve optimal performance.

Another benefit of the SPR507B design is the ability to update the sFPDP implementation at some point in the future. The current draft VITA17.2 specification allows for key additional features such as channel bonding. Future updates can be accomplished by simply updating the firmware on the card.

### FEATURES:

- Four sFPDP ports
- Supports up to 4.25Gb/s per port
- Each port can operate independently (direction) with a unique DMA engine per port
- Four lane PCI Express Gen2 interface allows for high-speed data transfer to Host memory
- Available with either PMC or XMC interface to allow for wide range of host compatibility
- Available in five ruggedization levels with support for harsh environments and conduction cooling
- Supports copy mode (duplicates data from one fibre to another while optionally transferring data to Host)
- VITA 17.1 compliant, upgrade path to VITA 17.2
- 1 GB onboard storage
- VxWorks, Microsoft® Windows® and Linux® Software Development Kits

# SPR507B 4-Channel Serial FPDP Interface PMC/XMC Module with PCI Express x4 Gen 2 Interface

## Specifications

### Data Ports

- Four fibre optic transceivers
- Choice of 850nm (up to 500m) or 1300nm (up to 10km) transceivers
- Supports baud rates of 1.0625, 2.125, 2.5, 3.125, or 4.25 Gbaud/s
- Supports interrupts for detecting link activity or remote enable control signal
- VITA 17.1 compliant

### General

- XMC/PMC form factor

### Environmental

- Ruggedization levels 1 through 5
- -40°C to +85°C Storage
- Humidity <95% non-condensing

### Power

- ~ 24W

### Software

- VxWorks, Windows and Linux Software Development Kits
- Software Development Kits (SDK) include API and application examples

## Block diagram

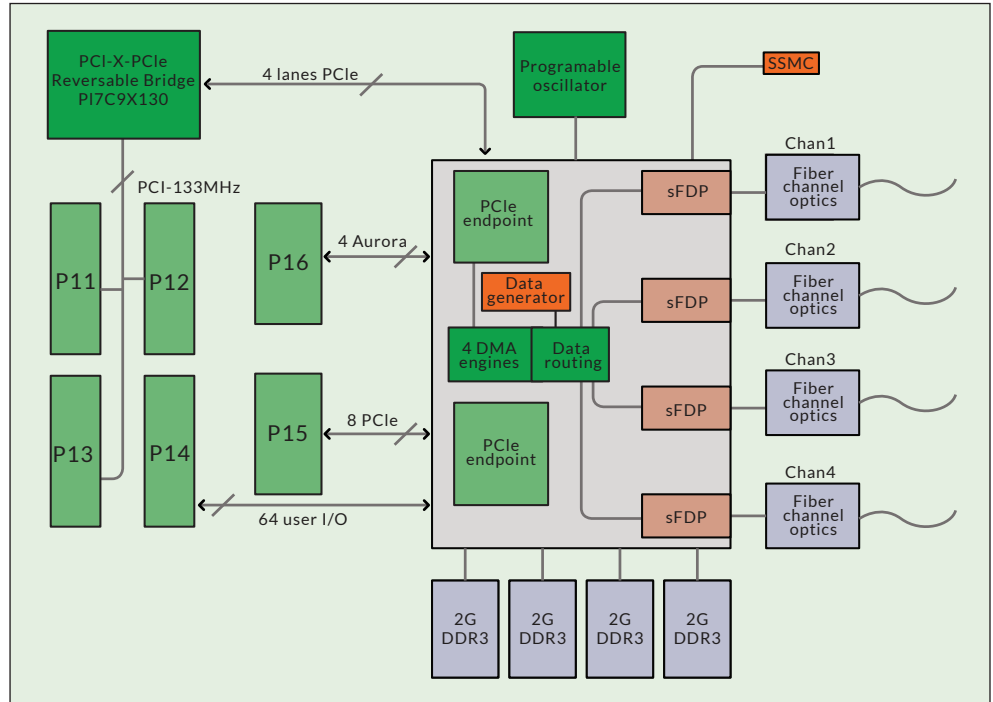

## Ordering information

SPR507B-X00	4 port PMC module, 850nm, rugged level X (1-5)
SPR507B-X01	4 port XMC module, 850nm, rugged level X (1-5)
SVXW-SPR507B-0YSC	Software development kit for VxWorks (VxBus) operating system
SWIN-SPR507B-0YSC	Software development kit for Windows XP and Vista operating systems
SLIN-SPR507B-0YSC	Software development kit for Linux operating system

Cable options are available. Contact your sales representative for details.

WE INNOVATE. WE DELIVER. YOU SUCCEED.

Americas: 866-OK-ABACO or +1-866-652-2226 Asia & Oceania: +81-3-5544-3973

Europe, Africa, & Middle East: +44 (0) 1327-359444

Locate an Abaco Systems Sales Representative visit: [abaco.com/products/sales](http://abaco.com/products/sales)

[abaco.com](http://abaco.com) @AbacoSys

©2016 Abaco Systems. All Rights Reserved. All other brands, names or trademarks are property of their respective owners. Specifications are subject to change without notice.

